

# **CM-iGLX Computer-On-Module**

## **Reference Guide**

## **Table of Contents**

<b>1. Revision Notes .....</b>	<b>4</b>
<b>2. Overview.....</b>	<b>5</b>
2.1. HIGHLIGHTS .....	5
2.2. BLOCK DIAGRAM .....	6
2.3. FEATURES.....	7
2.4. GENERAL DESCRIPTION.....	9
2.5. AMD "LX" CPU CORE ARCHITECTURE .....	10
2.6. NAND FLASH DISK .....	11
<b>3. Peripherals and Functions .....</b>	<b>12</b>
3.1. WATCHDOG.....	13
3.2. REAL-TIME CLOCK.....	13
3.3. DISPLAY CONTROLLER.....	15
3.4. GENERAL PURPOSE INPUT / OUTPUT .....	18
3.5. PCI BUS HOST BRIDGE .....	19
3.6. AC97 INTERFACE.....	23
3.7. LPC - LOW PIN COUNT INTERFACE.....	25
3.8. SERIAL PORTS .....	25
3.9. USB PORTS .....	27
3.10. AUDIO INTERFACE.....	27
3.11. TOUCH SCREEN CONTROLLER.....	29
3.12. HARD DISK CONTROLLER - PARALLEL ATA .....	30
3.13. 10/100 MBIT ETHERNET PORT .....	32
3.14. JTAG INTERFACE.....	35
3.15. CLOCKS, TIMERS, RESET, WRITE PROTECT, BOOT, POWER MANAGEMENT .....	36
3.16. SMBUS (I2C) .....	37
3.17. POWER SUPPLY PINS .....	37
3.18. RESTRICTIONS ON USING PULL-UPS / PULL-DOWNS.....	39
3.19. UNCONNECTED PINS.....	39
<b>4. Interface Connectors .....</b>	<b>41</b>
4.1. CONNECTOR TYPE .....	41
4.2. CONNECTOR LAYOUT.....	42
4.3. CONNECTORS PINOUT .....	43
<b>5. MEMORY and I/O mapping.....</b>	<b>49</b>
5.1. MEMORY SPACE USAGE IN THE FIRST 1MB.....	49
5.2. MEMORY SPACE USAGE ABOVE FIRST 1MB .....	49
5.3. I/O SPACE USAGE.....	50
5.4. BIOS FLASH MAPPING.....	51
<b>6. Power Consumption .....</b>	<b>52</b>

<b>7. Performance Benchmarks.....</b>	<b>52</b>
<b>8. Operating Temperature Ranges.....</b>	<b>53</b>

## 1. Revision Notes

Date	Description
30-Jun-2006	▪ Preliminary release
27-Nov-2006	▪ Audio sampling rate errata published
06-May-2007	▪ UCB1400 (audio codec) reference replaced by WM9715L, as design change. Functionality remains the same. ▪ Made clarifications about SMBus signals.
27-Nov-2007	▪ Added Power sequence notes
26-Dec-2007	▪ Published WiFi specifications in datasheet section

Please check for a newer revision of this manual in CompuLab's website - <http://www.compulab.co.il>, following [Developer] >> [iGLX] links. Compare the revision notes of the updated manual from the website with those of the printed version you have.

## 2. Overview

### 2.1. Highlights

<ul style="list-style-type: none"> <li>• <b>Full Featured PC-Compatible Computer-On-Module</b></li> <li>• <b>AMD Geode LX800 CPU at 500 MHz, 256 KB cache</b></li> <li>• <b>256 Mbyte DDR</b></li> <li>• <b>512 Mbyte Flash Disk</b></li> <li>• <b>Graphics Controller for LCD and FPM, up to 1920 x 1440</b></li> <li>• <b>General purpose bus and optional PCI, LPC, AC97 busses</b></li> <li>• <b>WLAN / WiFi 802.11g Interface</b></li> <li>• <b>Video Input Port</b></li> <li>• <b>Sound codec with speaker and microphone support</b></li> <li>• <b>Touchscreen Controller</b></li> <li>• <b>Up to 3 host USB-2 ports, including keyboard and mouse support</b></li> <li>• <b>Serial ports, GPIO, hard-disk interface</b></li> <li>• <b>100 Mbps Ethernet port</b></li> <li>• <b>Low power consumption</b></li> <li>• <b>Small size - 68 x 58 mm</b></li> <li>• <b>Interchangeable with other modules via CAMI connectors</b></li> </ul> <p><i>Note: Some features are optional. Values are specified at their maximum.</i></p>	<p><b>The CM-iGLX</b> packs up-to-date technologies into the most compact, lightweight PC-on-module available in the market. Its on-board resources suffice to smoothly run operating systems such as Linux and Windows XP / CE, while it is just as small as a credit card and can run on a battery. These, in addition to the module's low cost, make it an ideal building block for any embedded application.</p> <p>The feature set of the CM-iGLX combines a 32-bit X86-compatible CPU, DDR, Flash Disk and vital computing peripherals. For embedded applications, the CM-iGLX provides a 32-bit PCI bus, 100Mbit Ethernet, serial ports, general purpose I/O lines and many other essential functions. The user interface is supported by an enhanced graphics controller, touchscreen, USB interface for keyboard / mouse and Audio system. An integrated WLAN (WiFi) interface implements 802.11g industry standard wireless connectivity.</p> <p>The standardized CAMI ("CompuLab's Aggregated Module Interface") connectors of the CM-iGLX module allow interchangeability with other Computer-On-Module's available from CompuLab, enabling the flexibility required in a dynamic market where application requirements can change rapidly.</p>
---	---

## 2.2. Block Diagram

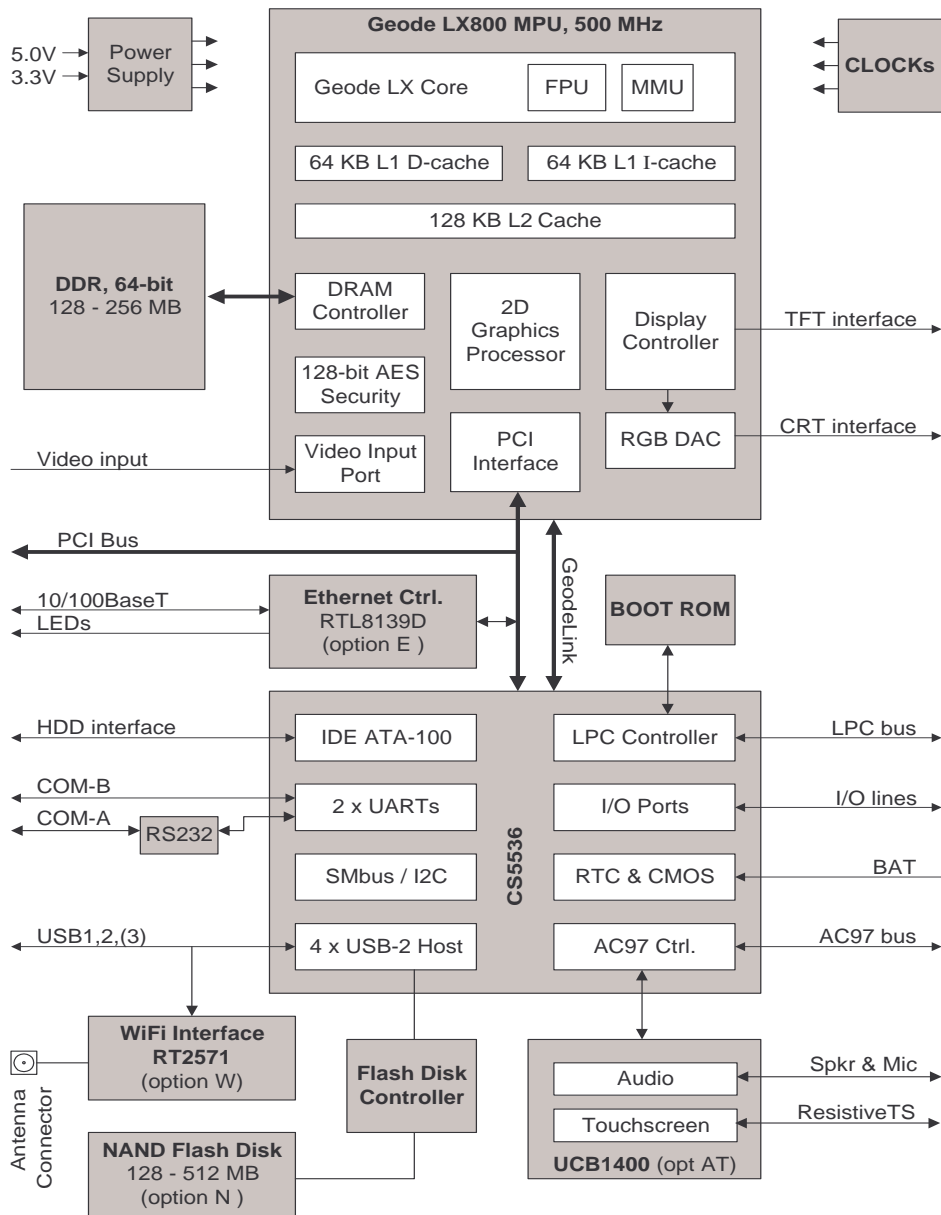

### 2.3. Features

The "Option" column specifies the P/N code required to have the particular feature. "+" indicates that the feature is always available.

#### CPU, Memory and Busses

Feature	Specifications	Option
CPU	AMD LX800 / LX700 CPU, Pentium compatible, up to 500 MHz. 64 + 64 KB L1 and 128 KB L2 cache. DMA and Interrupt controllers, Timers	C
DRAM	128 / 256 MB DDR, 333 MHz, 64-bit	D
BIOS Flash	1/2 Mbyte, on-board reprogrammable	+
NAND Flash Disk	128 / 512 MB, more in future. 10 MB/s transfer rate.	N
External Busses	PCI, LPC, AC97	+
AC97	AC97 Rev 2.3 compliant	+
PCI bus	32-bit, rev 2.2-compliant, 132 MB/s, 3.3-volt tolerant Arbiter and clock for one or two masters	+
LPC bus	Host, 33 MHz, Intel LPC v1.0 compatible	+

**Peripherals**

Feature	Specifications	Option
Graphics Controller	Resolution up to 1920 x 1440 x 32 bpp @ 85Hz, frame buffer in system memory, 2D graphic processor	+
Display Interface	LCD - 18-bit parallel RGB for TFT panels CRT - 24-bit analog RGB for CRT / FPM	+ +
Video Input Port	VESA1.1 & VESA2.0 standard, BT.601, BT.656, 8-bit port, 150 MHz data rate	+
USB	Three Host USB 2.0 ports, 480 Mbps, EHCI / OHCI compliant	+
Serial Ports	Two UART's, Rx & Tx only	+
GPIO	4 lines dedicated + 4 lines shared	+
Hard Disk Interf.	IDE interface, UDMA ATA-100 mode	+
Kbrd & Mouse	USB or redirection from serial port	+
Ethernet	100 Mb/s, Activity LED's. RTL8139	E
Audio codec	Wolfson WM9715L controller, AC97 interface, mono microphone input, stereo line input and 25 mW output for active speakers	AT
Touchscreen ctrl.	A part of the WM9715L chip. Supports resistive touch panels	AT
RTC	Real Time Clock, powered by external lithium battery	+
WiFi	Ralink RT2571 chipset, 802.11b/g, USB internal interface	W
Encryption unit	128 bit DMA based crypto acceleration block up to 44 Mbps	+

**Electrical, Mechanical and Environmental Specifications**

Supply Voltage	3.3V
Power consumption	3 - 5 W, depending on configuration and CPU speed
Dimensions	68 x 58 x 8 mm
Weight	37 gram
MTBF	> 100,000 hours
Operation temperature (case)	Commercial : 0° to 70° C Extended : -20° to 70° C Industrial : -40° to 85° C
Storage temperature	-40° to 85° C
Relative humidity	10% to 90% (operation) 05% to 95% (storage)
Shock	50G / 20 ms
Vibration	20G / 0 - 600 Hz

Connectors	3 x 140 pin, 0.6 mm. Insertion / removal up to 50 cycles
------------	--

## 2.4. General Description

The CM-iGLX is a miniature, single-board computer packed as a module. It contains a CPU, chipset, memory, flash disk and peripherals. All interface functions of the CM-iGLX are routed through miniature high-density connectors, designed for piggyback attachment to a custom baseboard, as shown in the picture below.

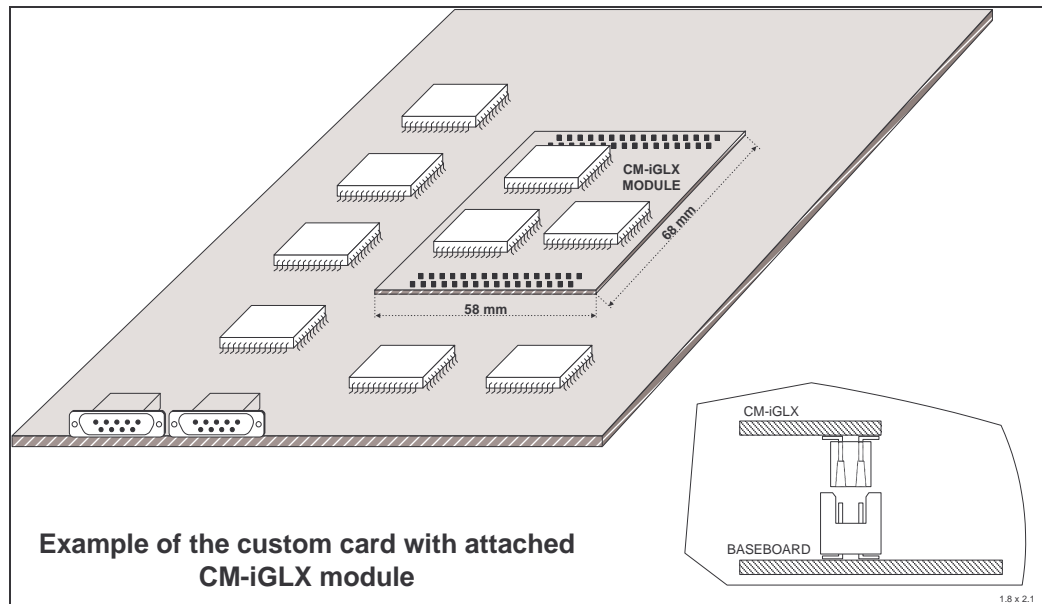

## **2.5. AMD "LX" CPU Core Architecture**

The x86 CPU core consists of an Integer Unit, cache memory subsystem, and Floating Point Unit. The Integer Unit contains the instruction pipeline and associated logic. The memory subsystem contains the instruction and data caches, translation look-aside buffers (TLBs), and an interface to the GeodeLink Interface Units (GLIUs).

The instruction set supported by the core is a combination of Intel's Pentium, the AMD-K6 microprocessor and the Athlon FPU, and the AMD Geode LX processor specific instructions. Specifically, it supports the Pentium, Pentium Pro, 3DNow technology for the AMD-K6 and Athlon processors, and MMX instructions for the Athlon processor. It supports a subset of the specialized Geode LX processor instructions including special SMM instructions. The CPU Core does not support the entire Katmai New Instruction (KNI) set as implemented in the Pentium 3. It does support the MMX instructions for the Athlon processor, which are a subset of the Pentium 3 KNI instructions.

AMD LX processor architecture is relatively simple: instructions are issued, executed and retired in order, one instruction issued per clock. On the other hand, the design is highly optimized to achieve high performance in the targeted environment. Some of the significant features providing this performance are:

### **Large on-chip caches and TLB's:**

The AMD "LX" CPU implements large caches and TLB's that significantly reduce stalls due to bus traffic:

- Two 64-KB primary (L1) caches with 16-way associativity
- A 4-way 128-KB unified level-2 (L2) victim cache
- A 16-entry TLB (TLB1) with fully associativity
- A 64-entry TLB (TLB2) with 2-way associativity

### **Extensive features to minimize bus stalls:**

- Full memory type range registers (MTRR's)
- A non-stalling write-allocate implementation
- Efficient prefetch and branch prediction
- Integrated FPU that supports the MMX® and AMD 3DNow!™ instruction sets
- Fully pipelined single precision FPU hardware with microcode support for higher precision

**AMD "LX" processor Architecture Block Diagram**

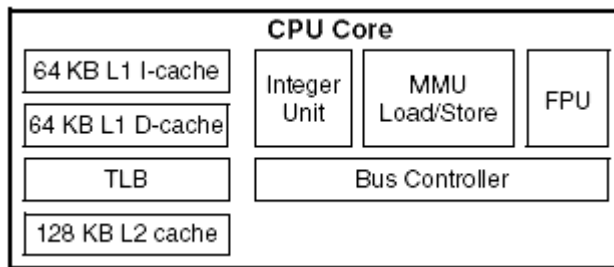

**Security Block**

The Geode LX processor has an on-chip AES 128-bit crypto acceleration block capable of 44 Mbps throughput on either encryption or decryption at a processor speed of 500 MHz. The AES block runs asynchronously to the processor core and is DMA-based. The AES block supports both EBC and CBC modes. The initialization vector for CBC mode can be generated by the True Random Number Generator (TRNG). The TRNG is addressable separately and generates a 32-bit random number.

**2.6. NAND Flash Disk**

CM-iGLX contains on-board NAND flash disk, supported by all operating systems available from CompuLab. The Flash Disk behaves exactly like a regular hard disk drive; however, it doesn't have any moving parts.

The NAND Flash is a block device - optimized for block read and write operations rather than for random access. CM-iGLX also contains on-board Flash Disk Controller, which takes care for translation between operating system commands and NAND flash read/write operations. The controller connected to CPU through USB port. In addition to the flash disk emulation, the controller implements error correction (ECC), write protection and caching for improved performance.

The NAND Flash size is 128 or 512 Mbytes. The CM-iGLX is designed for upward compatibility with future NAND Flash devices of larger capacity.

**Performance**

Read	5000 KB/s
Write	840 KB/s

### 3. Peripherals and Functions

#### Interrupt Channel Mapping

IRQ	I/O Device	Priority	On-board usage
IRQ0	PIT 0	P1	always
IRQ1	-	P2	-
IRQ2	Slave controller cascading	—	always
IRQ3	COM B, off-board PCMCIA	P11	-
IRQ4	COM A, off-board PCMCIA	P12	always
IRQ5	PCI	P13	-
IRQ6	-	P14	-
IRQ7	Off-board PCMCIA	P15	-
IRQ8	Real-time clock	P3	always
IRQ9	PCI	P4	-
IRQ10	PCI	P5	-
IRQ11	PCI	P6	-
IRQ12	-	P7	-
IRQ13	Floating point error	P8	always
IRQ14	IDE	P9	-
IRQ15	Off-board PCMCIA	P10	-

If the IRQ is used by the on-board device, disabling the device will free the IRQ. If the on-board device cannot be disabled, then the IRQ is *always* assigned for on-board usage and is therefore marked accordingly in the table above. PCI interrupts support sharing, i.e., the same interrupt may be used by several on-board and off-board devices.

#### Serial IRQ

Serial IRQ allows a single signal line to be used to report the legacy ISA interrupt requests. Interrupt sharing is allowed on Serial IRQ interfaces only for the devices external to the chipset. The following interrupts are external to the chipset and are therefore potentially available on the Serial IRQ interface: IRQ1, IRQ6, IRQ7, IRQ12 and IRQ15. The serial IRQ interface is a synchronous interface. Data is clocked by the system's PCI clock.

**Serial IRQ interface**

Signal	Pin	Type	Description
SERIRQ	P2-13	I/O	The routing for this signal must follow PCI layout/routing rules

**3.1. Watchdog**

A watchdog is available on the CS5536 companion chip. The timer has a 16-bit counter that counts up until the programmed value using 1 Hz clock. The comparator is loaded with an initial value and start counts from zero. On reaching the programmed value, it generates a system reset. The timer's status can be read and updated at any time. The watchdog can be de-activated and re-activated. A driver and sample application for watchdog operation is provided in the O/S packages.

**3.2. Real-Time Clock**

The RTC is compatible with the standard used in PC/AT systems. The RTC consists of a time-of-day clock with an alarm interrupt and a 100-year calendar. The clock / calendar has a programmable periodic interrupt, 242 bytes of static user RAM and can be represented in either binary or BCD. The RTC includes the following features:

- Counting of seconds, minutes and hours of the day
- Counting of days of the week, date, month and year
- 12–24 hour clock with an am/pm indicator in 12-hour mode
- 242 bytes of general-purpose RAM
- Three separate software-maskable and testable interrupts: (1) time-of-day alarm is programmable to occur from once-per-second to once-per-month, (2) periodic interrupts can be configured to occur at rates from 3.9 ms to 500 ms, and (3) update-ended interrupt provides cycle status.
- The voltage monitor circuit checks the voltage level of the backup lithium battery and sets a bit when the battery voltage level falls below specification.
- The internal RTC reset signal performs a reset when power is applied to the RTC core.

The RTC uses a dedicated lithium backup battery when the rest of the card is completely powered down (RTC-only mode). The RTC can continue operating even when the rest of the card is not powered. The battery should be connected to the VCC-RTC input of the CM-iGLX's interface connector. The equivalent RTC supply circuit is shown in the figure below.

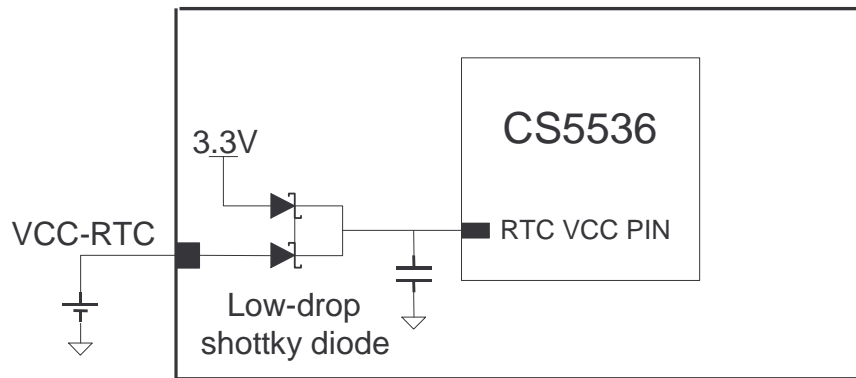

	Typical	Max
VCC-RTC Input Current (Rest of the card powered down)	2 $\mu$ A	6 $\mu$ A

### Storing of BIOS Settings

The CM-iGLX's BIOS has two sets of stored settings:

1. Current settings stored in CMOS memory, backed-up by battery as described above. The battery is not located on the CM-iGLX itself, but rather should be provided on the baseboard. When the CMOS is not powered, the settings it saves are lost.
2. Default settings saved in Flash memory. These settings remain valid when the card is not powered, even in the absence of battery backup. The user can update the Flash default settings to any values desired.

On startup, the BIOS checks if valid CMOS settings are available. If they are, BIOS takes the settings from the CMOS. Flash defaults are ignored in that case. If CMOS settings are not valid (i.e., were erased), BIOS uses the default settings from the Flash. In this case, BIOS also copies the default settings from the Flash to the CMOS, to make its contents valid.

### **3.3. Display Controller**

The powerful Display Controller of the CM-iGLX contains a comprehensive set of features required for multimedia applications:

#### **Integrated Graphics / Video Accelerator**

- Optimized Unified Memory Architecture (UMA)
- Hardware frame buffer compression
- 2 to 128 MB frame buffer using system memory
- Simultaneous CRT / TFT Support
- Resolutions up to 1920x1440x32 bpp at 85 Hz, or up to 1600x1200x32 bpp at 100 Hz
- Supports down to 7.652 MHz Dot Clock (320x240QVGA)
- Hardware legacy VGA
- Hardware supported 48x64 32-bit cursor with alpha blending

#### **Extensive Display Support**

- Integrated Dot Clock PLL with up to 350 MHz clock
- Integrated 3x8-bit DAC with up to 350 MHz sampling

#### **Video Support**

- Supports video scaling and mixing
- Hardware video up/down scalar
- Graphics/video alpha blending and color key mixing
- TFT outputs
- Legacy RGB mode
- VESA 1.1, 2.0

#### **Video Input Port**

- VESA 1.1, 2.0 and BT.601, BT.656 compliant, 150 MHz (excludes host interface).
- Standard 9 pin interface (8 data + clock)
- 8-bit BT.656 video
- VIP 1.1 compatible mode (8 bit)
- 8-bit BT.601 type input video with HSYNC and VSYNC

**Display Controller Block Diagram**

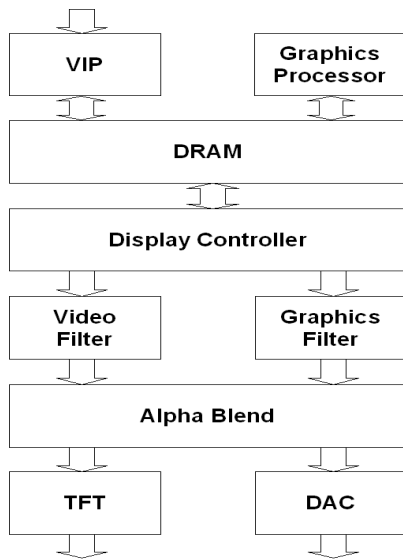

**LCD Panel Interface Signals**

Signal	Pin	Type	Description
LCD-B0	P3-126	O	<b>LCD Panel Data Bus.</b>
LCD-B1	P2-95	O	
LCD-B2	P2-97	O	
LCD-B3	P2-100	O	
LCD-B4	P2-99	O	
LCD-B5	P2-102	O	
LCD-G0	P2-101	O	
LCD-G1	P2-104	O	
LCD-G2	P2-106	O	
LCD-G3	P2-105	O	
LCD-G4	P2-108	O	
LCD-G5	P2-107	O	
LCD-R0	P3-128	O	
LCD-R1	P2-109	O	
LCD-R2	P2-113	O	
LCD-R3	P2-116	O	
LCD-R4	P2-118	O	
LCD-R5	P2-117	O	
LCD-SCK	P2-112	O	<b>Display Data Clock.</b> Pixel clock for flat panel data.
LCD-FRM	P2-111	O	<b>Frame Sync.</b> Flat Panel equivalent of VSYNC.
LCD-LP	P2-96	O	<b>Line Sync.</b> Flat Panel equivalent of HSYNC.
LCD-DE	P2-114	O	<b>Display Enable signal (DE)</b> for TFT Panels.
LCD-VDDEN	P3-130	O	Power sequencing control for panel driver electronics voltage VDD.

**CRT Interface Signals**

Signal	Pin	Type	Output Drive	Description
CRT-HSYNC	P3-129	O	1/4 mA	<b>CRT Horizontal Sync</b>
CRT-VSYNC	P3-140	O	1/4 mA	<b>CRT Vertical Sync</b>
CRT-R	P3-132	O	19 mA	<b>CRT analog video outputs</b> from the internal color palette DAC. The DAC is designed for a 37.5 ohm equivalent load on each pin (e.g., 75 ohm resistor on the board, in parallel with the 75 ohm CRT load)
CRT-G	P3-136	O	19 mA	
CRT-B	P3-133	O	19 mA	

**Video Input Port interface signals**

Signal	Pin	Type	Description
VIP-CLK	P3-88	I	Video Input Port clock input
VIP-D0	P3-80	I	Video Input Port data input
VIP-D1	P3-82	I	Video Input Port data input
VIP-D2	P3-84	I	Video Input Port data input
VIP-D3	P3-90	I	Video Input Port data input
VIP-D4	P3-92	I	Video Input Port data input
VIP-D5	P3-94	I	Video Input Port data input
VIP-D6	P3-96	I	Video Input Port data input
VIP-D7	P3-89	I	Video Input Port data input

**3.4. General Purpose Input / Output**

The CS5536 companion chip integrated in the CM-iGLX provides 8 general purpose I/O pins (GPIO's) – four dedicated and the other four shared with alternative functions.

GPIO sample code is available in o/s packages provided by CompuLab.

The dedicated GPIO's are:

Signal	Pin	Type	Remarks
GPIO6	P1-13	I/O	Autosense weak PU/PD
GPIO5	P1-16	I/O	Autosense weak PU/PD
GPIO27	P1-15	I/O	Configurable PU/PD, controls Power Led
GPIO25	P1-18	I/O	Configurable PU/PD

GPIO's shared with alternative functions:

Default configuration	Pin	Type	Remarks	On board usage
TIMER-OUT [GPIO1]	P3-61	I/O	Configurable PU	-
LPC-LDRQ [GPIO20]	P2-17	I/O	PU 8.2k	-
SERIRQ [GPIO21]	P2-13	I/O	PU 8.2k	-
PME [GPIO26]	P1-17	I/O	Configurable PU/PD	+

\* GPIO references are specified according to enumeration used in CS5536 manual.

### 3.5. PCI Bus Host Bridge

The CM-iGLX contains an integrated PCI bus host bridge allowing interface to any PCI bus Revision 2.2-compliant master or target device. The PCI host bridge on the CM-iGLX has the following functionality:

- **Master controller** - Allows the CPU to be a master on the PCI bus. The CPU can generate transactions to configure the PCI host bridge, as well as all external devices on the PCI bus. The CPU can also generate memory and I/O read and write transactions on the PCI bus.
- **Target controller** - Allows external PCI bus masters to access the CM-iGLX's on-board DRAM.

#### Features:

- 33 MHz operation
- Target support for fast back-to-back transactions
- Arbiter support for one or two external PCI bus masters
- Write gathering and write posting for in-bound write requests
- Virtual PCI header support
- Delayed transactions for in-bound read requests
- Zero wait state operation within a PCI burst
- Dynamic clock stop/start support
- Capable of handling out-of-bounds transactions immediately after reset
- PCI-2.2 compliant, 32 bit 3.3V PCI interface

#### PCI Clock System

The clock source is from an on-board oscillator. The CM-iGLX acts as a 'motherboard', providing clocks to all other parts of the application. If a developer needs to synchronize PCI bus operation with another clock source from a custom baseboard, then a PCI-to-PCI bridge should be used. (Suitable bridges are available from PLX and other manufacturers.)

The PCI standard allows up to a 2ns clock skew. In order to minimize the initial skew value, the internal feedback path is designed with a 10 cm trace length - to create the initial delay. Feedback is provided to the clock generation block of the PCI bridge. The timing of all internal clock references is shifted accordingly. In other words, PCI signals are pre-compensated for an external clock trace length of 10 cm. The maximum allowed length of the external clock trace is:

10 cm (pre-compensated) + 30 cm (max propagation delay for a skew less than 2ns)

**PCI Bus Signals**

<b>Signal</b>	<b>Pin</b>	<b>Type</b>	<b>Description</b>
PCI-AD0	P2-20	B	<b>PCI Address Data Bus</b>
PCI-AD1	P2-22	B	
PCI-AD2	P2-21	B	
PCI-AD3	P2-24	B	
PCI-AD4	P2-23	B	
PCI-AD5	P2-25	B	
PCI-AD6	P2-28	B	
PCI-AD7	P2-27	B	
PCI-AD8	P2-29	B	
PCI-AD9	P2-32	B	
PCI-AD10	P2-34	B	
PCI-AD11	P2-33	B	
PCI-AD12	P2-36	B	
PCI-AD13	P2-35	B	
PCI-AD14	P2-37	B	
PCI-AD15	P2-40	B	
PCI-AD16	P2-51	B	
PCI-AD17	P2-54	B	
PCI-AD18	P2-53	B	
PCI-AD19	P2-56	B	
PCI-AD20	P2-58	B	
PCI-AD21	P2-57	B	
PCI-AD22	P2-60	B	
PCI-AD23	P2-59	B	
PCI-AD24	P2-64	B	
PCI-AD25	P2-63	B	
PCI-AD26	P2-66	B	
PCI-AD27	P2-65	B	
PCI-AD28	P2-68	B	
PCI-AD29	P2-70	B	
PCI-AD30	P2-69	B	
PCI-AD31	P2-72	B	

**PCI Bus Signals (continued)**

Signal	Pin	Type	Description
PCI-CBE0#	P2-30	B	<b>Command or Byte-Enable Bus</b> functions: (1) as a time-multiplexed bus command that defines transaction type on the AD bus, or (2) as byte enables: CBE0 for AD7–AD0
PCI-CBE1#	P2-39	B	<b>Command or Byte-Enable Bus</b> functions: (1) as a time-multiplexed bus command that defines transaction type on the AD bus, or (2) as byte enables: CBE1 for AD15–AD8
PCI-CBE2#	P2-52	B	<b>Command or Byte-Enable Bus</b> functions: (1) as a time-multiplexed bus command that defines transaction type on the AD bus, or (2) as byte enables: CBE2 for AD23–AD16
PCI-CBE3#	P2-61	B	<b>Command or Byte-Enable Bus</b> functions: (1) as a time-multiplexed bus command that defines transaction type on the AD bus, or (2) as byte enables: CBE3 for AD31–AD24
PCI-DEVSEL#	P2-45	B	<b>Device Select</b> is asserted by the target when it has decoded its address as the target of the current transaction. This signal is pulled up on-board with an 8.2K resistor.
PCI-FRAME#	P2-49	B	<b>Frame</b> is driven by the transaction initiator to indicate the start and duration of the transaction. This signal is pulled up on-board with an 8.2K resistor.
PCI-INTA#	P2-6	I	<b>PCI Interrupt Requests</b> is asserted to request an interrupt.
PCI-INTB#	P2-8	I	
PCI-INTC#	P3-20	I	
PCI-INTD#	P3-17	I	
PCI-IRDY#	P2-47	B	<b>Initiator Ready</b> is asserted by the current bus master to indicate that data is ready on the bus (write) or that the master is ready to accept data (read). This signal is pulled up on-board with an 8.2K resistor.
PCI-PAR	P2-42	B	<b>PCI Parity</b> is driven by the initiator or target to indicate parity on the AD31–AD0 and CBE3–CBE0 busses.
PCI-PERR#	P2-44	B	<b>Parity Error</b> is not supported. This signal is pulled up on-board with an 8.2K resistor.
PCI-PCIRST#	P1-137	O	<b>Reset</b> is asserted to reset the PCI devices.

<b>Signal</b>	<b>Pin</b>	<b>Type</b>	<b>Description</b>
PCI-SERR#	P2-41	I	<b>System Error</b> is not supported. This signal is pulled up on-board with an 8.2K resistor.
PCI-STOP#	P2-46	B	<b>Stop</b> is asserted by the target to request that the current bus transaction be stopped. This signal is pulled up on-board with an 8.2K resistor.
PCI-TRDY#	P2-48	B	<b>Target Ready</b> is asserted by the currently addressed target to indicate its ability to complete the current data phase of a transaction. This signal is pulled up on-board with an 8.2K resistor.
PCI-REQ0# PCI-REQ1#	P2-1 P2-18	I	<b>Bus Request</b> is asserted by the master to request access to the bus. PCI_REQ1# is available only if on-board Ethernet chip is not assembled.
PCI-GNT0# PCI-GNT1#	P2-3 P2-5	O	<b>Bus Grant</b> is asserted by the CM-iGLX to grant access to the bus. PCI_GNT1# is available only if on-board Ethernet chip is not assembled.
PCI-CLK0 PCI-CLK1 PCI-CLK2	P2-16 P3-16 P3-24	O	<b>PCI Bus Clock Output</b> is a 33-MHz clock for PCI bus devices. This signal is derived from an onboard 33MHz source. Clock edge position is internally compensated in order to reduce skew to a minimum.

**Notes**

1. Output drive and maximum load specifications are according to PCI bus Standard Rev-2.2.
2. PCI Bus inputs / outputs inputs are 3.3V-level

**PCI resource map**

Device	IDSEL line	PCI dev. / func.	IRQ
CM-iGLX Host bridge	AD11	0x01,func.0	
CM-iGLX display controller	AD11	0x01, func. 1	11
CM-iGLX Encryption Device	AD11	0x01, func. 2	11
ATX baseboard PCI Slot	AD18	0x08, func. 0	10,11
ATX baseboard CardBus bridge skt. A	AD19	0x09, func. 0	10
ATX baseboard CardBus bridge skt. B	AD19	0x09, func. 1	11
ATX baseboard Ethernet	AD20	0x0A, func. 0	11
CM-iGLX Ethernet	AD23	0x0D,func. 0	11
CM-iGLX internal ISA bridge	AD25	0x0F, func. 0	-
CM-iGLX IDE controller	AD25	0x0F, func. 2	14
CM-iGLX audio controller	AD25	0x0F, func. 3	11
USB 1.1 controller	AD25	0x0F, func. 4	5
USB 2.0 controller	AD25	0x0F, func. 5	5

PCI devices have no hardcoded IRQ assignment. The IRQ assignment listed in the table is correct for a CM-iGLX plugged into a CompuLab baseboard (such as an ATX), but can change if additional hardware is attached.

**3.6. AC97 Interface**

The audio / modem link in the CM-iGLX is AC97 Revision 2.3 compliant, supporting two codecs with independent PCI functions for audio and modem. Microphone input and left and right audio channels are supported for a high-quality two-speaker audio solution. Audio codec is included on-board in the CM-iGLX.

Features Supported by the AC97:

- AC97 version 2.3 compliant interface to codecs: serial in (x2), serial out, sync out and bit clock in.
- Eight-channel buffered bus mastering interface
- Support for industry standard 16-bit pulse code modulated (PCM) audio format
- Support for any AC97 codec with Sample Rate Conversion (SRC)
- Transport for audio data to and from the system memory and AC97 codec
- Capable of outputting multi-channel 5.1 surround sound (Left, Center, Right, Left Rear, Right Rear, and Low Frequency Effects)

Hardware Includes:

- Three 32-bit stereo-buffered bus masters (two for output, one for input)
- Five 16-bit mono-buffered bus masters (three for output, two for input)
- AC Link Control block for interfacing with external AC97 codec(s)

By using an optional audio codec, the CM-iGLX module implements cost-effective, high quality, integrated audio. In addition, an AC97 soft modem can be implemented with the use of a modem codec.

### AC97 link signals

Signal	Pin	Type	Description
AC97-RST#	P3-124	O	<b>AC97 Reset:</b> Master H/W reset to external Codec(s)
AC97-SYNC	P3-125	O	<b>AC97 Sync:</b> 48 KHz fixed rate sample sync to the Codec(s)
AC97-BITCLK	P3-120	I	<b>AC97 Bit Clock:</b> 12.288 MHz serial data clock generated by the external Codec(s)
AC97-SDOUT	P3-123	O	<b>AC97 Serial Data Out:</b> Serial TDM data output to the Codec(s). AC_SDOOUT is sampled at the rising edge of PWROK as a functional strap.
AC97-SDIN0	P3-119	I	<b>AC97 Serial Data In 0:</b> Serial TDM data input from a Codec. The on-board Codec uses this line.

### 3.7. LPC - Low Pin Count Interface

The CM-iGLX implements an LPC Interface and Controller as described in the LPC 1.0 specification. The LPC bus provides a functional replacement for the interfacing of legacy ISA functions, such as an additional Super-I/O chip.

#### LPC bus signals

Signal	Pin	Type	Description
LPC-LAD0	P2-10	I/O	<b>LPC Multiplexed Command, Address, Data.</b>
LPC-LAD1	P2-9	I/O	
LPC-LAD2	P2-12	I/O	
LPC-LAD3	P2-11	I/O	
LPC-LDRQ#	P2-17	I	<b>LPC Serial DMA/Master Request Inputs:</b> DMA or bus master request
LPC-LFRAME#	P2-15	O	<b>LPC Frame:</b> Indicates the start of an LPC cycle, or an abort

In addition to the above signals, an LPC device should use a PCI clock and the PCIRST#.

### 3.8. Serial Ports

The CM-iGLX includes two serial ports (UART's). The UART's power up as 16450-compatible devices. They are switched to 16550 (FIFO) mode under the control of serial drivers specific to the operating system used. In FIFO mode, the receive and transmit circuitry are each enhanced by separate FIFO's to off-load repetitive service routines from the CPU.

The serial ports include the following features:

- Fully compatible with 16550 and 16450 devices (except modem)
- Extended UART mode
- UART mode data rates up to 1.5 Mbps
- Transmit deferral
- Automatic fallback to 16550 compatibility mode
- Selectable 16 and 32 level FIFO's
- DMA handshake signal routing for either 1 or 2 channels
- Support for power management

The first UART includes RS232 drivers, the second UART has a TTL signal level interface.

**Serial Port Signals**

<b>Signal</b>	<b>Pin</b>	<b>Interf</b>	<b>Type</b>	<b>Description</b>
COMA-RX	P1-22	RS232	I	<b>Serial Data In</b> receives the serial data from the external serial device or DCE into the internal serial port controller.
COMB-RX	P1-23	TTL	I	
COMA-TX	P1-24	RS232	O	<b>Serial Data Out</b> transmits the serial data from the internal serial port controller to the external serial device or DCE.
COMB-TX	P1-25	TTL	O	

### 3.9. USB Ports

The CM-iGLX provides three plus one optional USB-2 ports. The USB ports are Host Controller Interface (HCI) compliant. The HCI specification provides a register level description for a host controller, as well as common industry hardware/software interface and drivers. USB ports are supported by all O/S packages provided for CM-iGLX.

Features:

- USB v2.0 / EHCI v1.0 and USB v1.1 / OHCI v1.1 compatible
- Physical layer transceivers with optional over-current detection status on USB inputs

#### USB Port Signals

Signal	Pin	Type	Description
USB-OVC#	P2-133	I	<b>Overcurrent.</b> This signal indicates that the USB hub has detected an overcurrent on the USB. This pin has a 4.7k pull-up
USB1-N	P2-140	I/O	USB Port 1 Data Negative for Port 1
USB1-P	P2-138	I/O	USB Port 1 Data Positive for Port 1
USB2-N	P2-139	I/O	USB Port 2 Data Negative for Port 2
USB2-P	P2-137	I/O	USB Port 2 Data Positive for Port 2
USB3-N	P1-138	I/O	USB Port 3 Data Negative for Port 3
USB3-P	P1-136	I/O	USB Port 3 Data Positive for Port 3
USB4-N*	P1-139	I/O	USB Port 4 Data Negative for Port 4
USB4-P*	P1-137	I/O	USB Port 4 Data Positive for Port 4

\* If the NAND flash is assembled, this port is not available

### 3.10. Audio Interface

The CM-iGLX implements audio interface using a Wolfson WM9715L codec chip, which also includes a touch screen controller. The codec is an AC'97 2.1 compliant stereo audio codec designed for PC multimedia systems. It uses industry-leading delta-sigma and mixed signal technology. This advanced technology and its features are designed to help in enabling the design of PC 99 and PC 2001 compliant high-quality audio systems. The codec surpasses PC 99, PC 2001 and AC '97 2.1 audio quality standards. The audio system also includes a power amplifier for matching the stereo output for a direct connection of stereo headphones.

## Features:

- Integrated High-Performance Headphone Amplifier
- Sample Rate Converters
- 20-bit Stereo Digital-to-Analog Converters
- 18-bit Stereo Analog-to-Digital Converters
- Line-level Stereo Input for LINE IN
- Microphone Input
- Integrated High-Performance Microphone Pre-Amplifier
- Meets or exceeds Microsoft PC 99 and PC 2001 Audio Performance Requirements

**Audio specifications**

Speaker Output	Type	Stereo
	Power	25 mW/ch into 32 ohm speakers
	Decoupling	Requires external 220uF capacitors, for 8 ohm load. Smaller capacitors (like 1uF) can be used for high-impedance loads.
Microphone Input	Type	Mono, electret or dynamic
	Decoupling	On-board
Line Input	Type	Stereo
	Decoupling	On-board

**Audio Interface Signals**

Signal	Pin Number	Type	Output Drive	Description
AUD-INL-MIC	P2-132	I	-	Audio stereo line input left and microphone mono input
AUD-INR	P2-130	I	-	Audio stereo line input right
AUD-OUTL	P2-131	O	25 mW	Speaker stereo output left. Can be used as line output
AUD-OUTR	P2-136	O	25 mW	Speaker stereo outputs right. Can be used as line output

**Audio System Errata**

USB1400 audio codec has a problem to operate at certain sampling rates: 11,025Hz, 22,050Hz, 44,100Hz. It has no problem to operate at other sampling rates: 8,000Hz, 12,000Hz, 16,000Hz, 24,000Hz, 32,000Hz & 48,000Hz, so these should be selected. Sound files included with operating system packages should be resampled to valid rates. Resampling can be performed by tools such as Audacity (<http://audacity.sourceforge.net/>)

Errata will be fixed until Jun-2007.

### 3.11. Touch Screen Controller

The optional Wolfson WM9715L codec chip includes a universal touch screen controller. Touch screen interface is for a 4-wire resistive touch screen, capable of performing position, pressure and plate resistance measurements.

Touchscreen is supported by certain operating system available for CM-iGLX. For details refer to [Products] >> [CM-iGLX] >> [O/S Support Coverage Map] page in CompuLab's web-site.

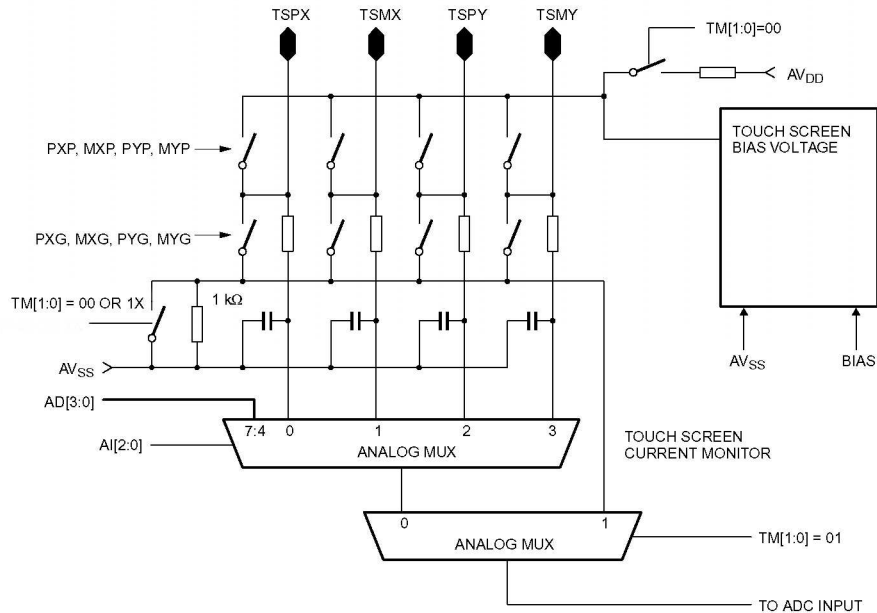

The touch screen interface connects to the touch screen by four wires: TSPX, TSMX, TSPY and TSMY. Each of these pins can be programmed to be floating, powered or grounded in the touch screen switch matrix. Each of the four touch screen signals can be selected as input for the built-in 10-bit ADC, which is used to determine the voltage on the selected touch screen pin in position measurement mode. In addition, the WM9715L can monitor touch screen current via an internal 1 Kohm resistor that can act as the input to the 10-bit ADC in pressure or plate resistance measurement mode. The flexible switch matrix and the multi-functional touch screen bias circuit enable the user of the WM9715L to set each desired touch screen configuration.

The WM9715L's internal voltage reference ( $V_{ref}$ ) acts as the reference voltage for the touch screen bias circuitry. This makes touch screen biasing independent of supply voltage and temperature variations. Four low-pass filters, one on each touch screen terminal, are

built-in to minimize the noise coupled from the LCD into the touch screen signals. An LCD typically generates large noise glitches on the touch screen, since they are closely coupled.

**Touch Screen Interface Signals**

Signal	Pin Number	Type	Description
TS-PX	P1-53	Analog	Plate X, plus (Left)
TS-MX	P2-71	Analog	Plate X, minus (Right)
TS-PY	P1-57	Analog	Plate Y, plus (Top)
TS-MY	P2-73	Analog	Plate Y, minus (Bottom)

**3.12. Hard disk Controller - Parallel ATA**

**Features**

- Single channel hard disk controller supporting two Enhanced IDE devices
- Transfer rate up to 100MB/sec
- UltraDMA-100/66/33 transfer protocol
- Support for legacy PIO mode 4 and multi-word DMA mode 2 drives
- DMA engine for concurrent operation, scatter-gather capability
- Bus master programming interface for SFF-8038i rev.1.0 and Windows compliant
- Support ATAPI compliant devices including DVD devices
- Support PCI native and ATA compatibility modes
- Complete software driver support under Linux and Windows

**Hard disk Interface Signals**

Note: connector signal names reflect the naming of PIO mode. In DMA mode, signal functionality is redefined.

Signal	Pin	Type	Description
IDE-CS0#	P1-47	O	<b>IDE Device Chip Select for 1F0h Range:</b> for ATA command register block
IDE-CS1#	P1-52	O	<b>IDE Device Chip Select for 3F6h Range:</b> for ATA control register block
LB-A0	P1-64	O	<b>IDE Device Address:</b> Used to indicate which byte in either the ATA command block or control block is being addressed
LB-A1	P1-63	O	
LB-A2	P1-66	O	

Signal	Pin	Type	Description
LB-D0	P1-94	I/O	<b>IDE Device Data</b>  IDE Address and Data lines are shared with "Local Bus" pins on CAMI connectors
LB-D1	P1-95	I/O	
LB-D2	P1-96	I/O	
LB-D3	P1-97	I/O	
LB-D4	P1-100	I/O	
LB-D5	P1-99	I/O	
LB-D6	P1-102	I/O	
LB-D7	P1-101	I/O	
LB-D8	P1-104	I/O	
LB-D9	P1-105	I/O	
LB-D10	P1-106	I/O	
LB-D11	P1-107	I/O	
LB-D12	P1-108	I/O	
LB-D13	P1-109	I/O	
LB-D14	P1-112	I/O	
LB-D15	P1-111	I/O	
IDE-DREQ	P3-63	I	<b>IDE Device DMA Request:</b> asserted by the IDE device to request a data transfer
IDE-DACK#	P3-65	O	<b>IDE Device DMA Acknowledge:</b> asserted to indicate to IDE DMA slave devices that a given data transfer cycle (assertion of RD# or WR#) is a DMA data transfer cycle
IDE-RD#	P1-46	O	<b>Disk I/O Read (PIO mode):</b> the command to the IDE device that it may drive data onto the IDE-D lines. Data is latched on the de-assertion edge of IDE-RD#. The IDE device is selected either by the ATA register file chip selects (IDE-CS0#, IDE-CS1#) and the IDE-A lines, or the IDE DMA acknowledge (IDE-DACK#). <b>Disk Write Strobe (UDMA Writes to Disk):</b> This is the data write strobe for writes to disk. <b>Disk DMA Ready (UDMA Reads from Disk):</b> This is the DMA ready for reads from disk.
IDE-WR#	P1-48	O	<b>Disk I/O Write (PIO and Non-UDMA):</b> the command to the IDE device that it may latch data from the IDE-D lines. Data is latched by the IDE device on the de-assertion edge of IDE-WR#. The IDE device is selected either by the ATA register file chip selects (IDE-CS0, IDE-CS1) and the IDE-A line, or the IDE DMA acknowledge (IDE-DACK#). <b>Disk Stop (UDMA):</b> the controller asserts this signal to terminate a burst.

Signal	Pin	Type	Description
LB-IORDY	P1-113 P3-66	I	<p><b>I/O Channel Ready (PIO):</b> keeps the strobe active (IDE-RD# or IDE-WR#) longer than the minimum width. It adds wait states to PIO transfers.</p> <p><b>Disk Read Strobe (UDMA Reads from Disk):</b> When reading from the disk, the controller latches data on rising and falling edges of this signal from the disk.</p> <p><b>Disk DMA Ready (UDMA Writes to Disk):</b> When writing to the disk, this is de-asserted by the disk to pause burst data transfers. This signal has an internal 1.5k pull-up.</p>

### 3.13. 10/100 Mbit Ethernet Port

The CM-iGLX contains one full-featured 10/100 Mbit Ethernet interface. The Ethernet interface is based on the on-board RTL8139 chip, supporting the following features:

- Integrated Fast Ethernet MAC, Physical chip and transceiver in one chip
- 10 Mb/s and 100 Mb/s operation
- 10 Mb/s and 100 Mb/s N-way Auto-negotiation operation
- PCI multi-function capabilities
- Two large (2Kbyte) independent receive and transmit FIFO's
- Programmable PCI burst size and early Tx/Rx threshold
- LED outputs for various network activity indications
- Loopback capability
- Half/Full duplex capability
- Full Duplex Flow Control (IEEE 802.3x)

#### Magnetic Modules

The CM-iGLX's Twisted Pair interface requires an external transformer (magnetic module) for interface to an RJ-45 connector. Two options exist:

1. An RJ-45 connector with a built-in transformer. Examples:

Vendor	Model
YCL	PTC1111-01
PCA	EPJ9025
Bothhand	LU1S041C

2. A separate transformer and RJ-45 connector. Examples of available transformers:

Vendor	Model
Delta	LF8200A
Pulse Engineering	PE-68515
Pulse Engineering	H1012

### Routing Ethernet Signals

The following rules should be applied when routing differential transmit and receive signals between the CM-iGLX interface connector and an external connector/transformer module:

1. Route the differential signal pairs (TXN, TXP) and (RXN, RXP) in parallel, with minimal and consistent clearance within the pair. The distance between RX and TX pairs should be maximized; otherwise, TX will induce crosstalk into RX.
2. It is preferable (but not mandatory) to keep the trace length of Ethernet signals as short as possible. If trace length exceeds 2 inches, additional steps, not specified here, should be taken. Recommended trace width: 5 to 8 mil.
3. Don't route any other traces near or across the Ethernet signals' path.
4. It is preferable (but not mandatory) to remove the ground and other planes from beneath the Ethernet trace area.

The listed rules cover the routing requirements if an RJ-45 connector with a built-in transformer is used. If a separate transformer is used, additional rules should be followed for transformer-to-connector routing.

**Ethernet Port Signals**

Signal	Pin	Type	Output Drive	Description
ETH1-TDN ETH1-TDP	P1-3 P1-1	A/O		<b>Analog Twisted Pair Ethernet Transmit Differential Pair.</b> These signals interface directly with an isolation transformer. TDP and TDN pins are connected by a 100 ohm termination resistor.
ETH1-RDN ETH1-RDP	P1-2 P1-4	A/I		<b>Analog Twisted Pair Ethernet Receive Differential Pair.</b> These pins receive the serial bit stream from the isolation transformer. RDP and RDN pins are connected by a 100 ohm termination resistor.
ETH1- ACT# (LED0)	P1-10	O	10 mA	<b>Activity LED.</b> The Activity LED pin indicates either transmit or receive activity. When activity is present, the output becomes low for a short time. When no activity is present, the line remains high.
ETH1- LINK100# (LED1)	P1-5	O	10 mA	<b>100 Link LED.</b> The 100 Link LED pin indicates link integrity and 100Mbps connection speed.
ETH1- LINK10# (LED2)	P1-6	O	10 mA	<b>10 Link LED.</b> The 10 Link LED pin indicates link integrity and 10 or 100 Mbps connection speed.

**Recommended LED connection**

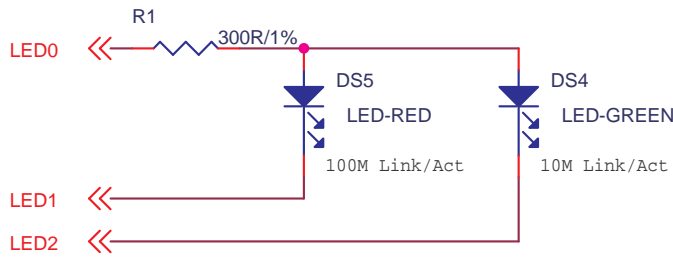

This connection supplies full information about speed/link/activity.

LED-RED with LED-GREEN: 100 Mbps link / activity indicator

LED-GREEN: 10 Mbps link / activity indicator

Activity	LED (Red/Green)
none	off
Link (only)	on
Tx / Rx (and Link)	blink

**3.14. JTAG interface**

- JTAG interface: ATPG, Full Scan, BIST on 1149.1 Boundary Scan compliant
- ICE (in-circuit emulator) interface
- Reset and clock control
- Designed for improved software performance analysis

**JTAG interface Signals**

Signal	Pin	Type	Description
JTAG-TCK	P3-77	I	<b>Test Clock</b> is the input clock for the test access port. This pin is tied to a 4.7k pull-up resistor.
JTAG-TDI	P3-83	I	<b>Test Data Input</b> is the serial input stream for input data. This pin is tied to a 4.7k pull-up resistor.
JTAG-TDO	P3-85	O/TS	<b>Test Data Output</b> is the serial output stream for result data. It is in high-impedance state except when scanning is in progress.
JTAG-TMS	P3-81	I	<b>Test Mode Select</b> is an input for controlling the test access port. This pin is tied to a 4.7k pull-up resistor.
JTAG-TRST#	P3-87	I	<b>JTAG Reset</b> is the test access port (TAP) reset.

### 3.15. Clocks, Timers, Reset, Write Protect, Boot, Power Management

Signal	Pin	Type	Description
RST-IN#	P1-11	I	Reset input, active low. Low level on this pin initiates a hardware reset of the CM-iGLX. The CM-iGLX will exist in reset state one second after deactivation of RST-IN. This pin is not mandatory for CM-iGLX operation, as it generates power-on reset using on-board circuitry. It has an internal pull-up and can be left unconnected.
RST-OUT#	P1-137	ODP	Reset output, active low. Indicates that CM-iGLX is undergoing a hardware reset, due to a power-up or RST-IN. Can be used as a reset signal to off-board hardware. RST-OUT minimum duration is approximately 0.5 seconds. The output type is open drain with a 10K pull-up resistor.
WP1#	P1-9	I	BIOS flash write protect. Writes to flash will be disabled if pulled to "0". To enable writes, pull this input to "1" or leave unconnected. This input has an internal pull-up.
WP2#	P3-100	I	NAND flash write protect, active low. NAND flash writes will be disabled if pulled to "0". To enable NAND flash writes, pull this input to "1" or leave unconnected. This input has an internal pull-up.
CLKOUT	P3-76	O	14.318 MHz clock output
TIMER-OUT	P3-61	O	General purpose timer of CS5536. Normally used as PC speaker in PC-compatible systems
PME	P1-17	I	Power management event / generic SMI source (for future use)
SUSP-IN	P1-21	I	Power button/sleep functionality
SLEEP_OUT#	P3-95	O	Sleep mode external device power disable/enable (for future use)
DEBUG1	P1-56	O	For factory use only. Should be left unconnected.
DEBUG0	P1-58	I	Irrelevant for any other purpose

### 3.16. SMBus (I2C)

The CM-iGLX provides a host system management bus interface. This interface is compatible with I2C devices.

Signal	Pin	Type	Description
SSI-DOUT SSI-DIN	P1-60 P1-59	I/O	SMBus data. Two pins are connected together on module. Note: CAMI connector defines separate In & Out pins, for compatibility with other serial interface standards. But CM-iGLX supports only standards having single bi-directional data signal.
SSI-CLK	P1-61	I/O	SMBus clock

Note: SPI mode is not supported.

### 3.17. Power Supply Pins

The CM-iGLX requires 3.3V supply for operation. All other required supply voltages are generated on-board using DC-DC converters. Supply voltage allowed variation is +/- 5%

#### Power Net Description

Signal	Description
GND	Common ground
VCC3_3	Main power supply, 3.3V. Used together with VCORE, tied to VCORE on-board.
VCC3_3SBY	Additional power supply used for DDR and stand-by mechanism. Should be connected to 3.3V stand-by power supply. Warning : connecting these ping to the regular VCC3_3 may lead to improper power sequencing and RTC problems (reset to default values). For reference design of proper power up sequencing see SB-iGLX schematics.
VCORE	Supply source for CPU core logic, should be 3.3V. Reduced to lower voltages by on-board converters. Compatibility note: when designing baseboard compatible with several CompuLab's CoM's, check VCORE voltage level requirements of all potential candidates. In some CoM's VCORE voltage is different than 3.3V. In such case you should design supply capable of providing the required range of voltages. On the other hand, if you intend to use only

	the CM-iGLX module, VCORE could be tied directly to the main 3.3V supply of the baseboard.
VCC5	This voltage is specified only for compatibility purpose. In CM-iGLX it can be connected either to 3.3V or to 5V. When designing baseboard compatible with several CompuLab's CoM's, check if other modules require that VCC5 will be 5V.
VCC-RTC	The 3.3 Volt supply pin provides power to the internal real-time clock and on-board static / configuration RAM. This pin can be driven independently of all other power pins. This pin enables the connection of an external lithium battery. The battery is not mandatory for the CM-iGLX, if the RTC function is not required. In such cases, the VCC-RTC pin should be left unconnected.

Note: all power pins must be connected.

Power sequence should be as below:

1. Apply VCC3SBY
2. Wait for SLEEP\_OUT# (P3-95, WORK\_AUX on the SB-iGLX) high and then enable VCC3\_3 rail.

Power down sequence :

1. SLEEP\_OUT# low will disable VCC3\_3 rail
2. Shut down VCC3SBY (or leave it connected and use PWRBTN signal for next power up).

**Power Supply Pins**

GND	P1-8, P1-14, P1-26, P1-38, P1-50, P1-62, P1-74, P1-86, P1-98, P1-110, P1-122, P1-134, P2-2, P2-14, P2-26, P2-38, P2-50, P2-62, P2-74, P2-86, P2-98, P2-110, P2-122, P2-134 P3-8, P3-14, P3-26, P3-38, P3-50, P3-62, P3-74, P3-86, P3-98, P3-110, P3-122, P3-134
VCC3_3	P1-31, P1-67, P1-103, P1-139 P2-7, P2-43, P2-79, P2-135 P3-19, P3-55, P3-91, P3-127, P3-135
VCC3_3SBY	P3-102, P3-104, P3-106, P3-107, P3-109, P3-111, P3-113
VCORE	P1-7, P1-19, P1-43, P1-55, P1-79, P1-91, P1-115, P1-127 P2-19, P2-31, P2-55, P2-67, P2-91, P2-103, P2-115, P2-127 P3-7, P3-31, P3-43, P3-67, P3-79, P3-103, P3-115
VCC5	P1-140, P3-131
VCC-RTC	P1-20

**3.18. Restrictions On Using Pull-ups / Pull-downs**

Some of the interface pins are also used as CPU pinstrap options. These pinstrap options are not relevant to the user; however, overriding them will lead to module malfunction. In any design, these pins must not have pull-up or pull-down resistors connected and must not be driven by any external source during boot.

Name	Pin	Pinstrap function
AC97-SYNC	P3-125	LPC/FWH BootROM
AC97-SDOUT	P3-123	LPC/FWH BootROM
PCI_GNT#0	P2-3	CPU frequency strap option
PCI_GNT#1	P2-5	CPU frequency strap option

**3.19. Unconnected Pins**

The following pins must be left unconnected for normal operation:

Name	Pin
SPARE5	P3-101
SPARE7	P3-105
PCM_BVD2	P3-113



## 4. Interface Connectors

The CM-iGLX connects to the external world through P1, P2 and P3 - 140-pin, 0.6 mm connectors.

### 4.1. Connector Type

	Mfg.	CM-iGLX Connector P/N	Mating Connector P/N
<b>P1, P2, P3</b>	AMP	1-5353183-0	1-5353190-0

#### Standoffs

CM-iGLX has four mounting holes for standoffs. Three of the mounting holes - two top and bottom right are connected to GND. The bottom left hole is isolated. (see drawings on the next page.) The developer is advised to connect the mating holes of the baseboard to GND, in order to improve EMC. The bottom left hole on the baseboard should be isolated, for compatibility with future CAMI modules.

The standoff is implemented by three parts: screw, spacer and nut:

	Description	Manufacturer and P/N
Screw	M2, 10 mm length	FCI 95121-005 Acton InoxPro BF22102010 World Bridge Machinery 380J52080
Spacer	M2x.4 thread, 4.2 mm length	Hirosugi ASU-2004 MAC8 2SP-4 World Bridge Machinery M2, L=4.2mm
Nut	M2, 1.6-2.0mm width	FCI 92869-001 (or 002) Acton InoxPro BG12102000 Bossard 1241397 (DIN934-A2 M2) World Bridge Machinery 381A52000

Mating connectors and standoffs are available from manufacturer representatives or from CompuLab. For details see [prices] >> [accessories] in CompuLab's website.

## 4.2. Connector Layout

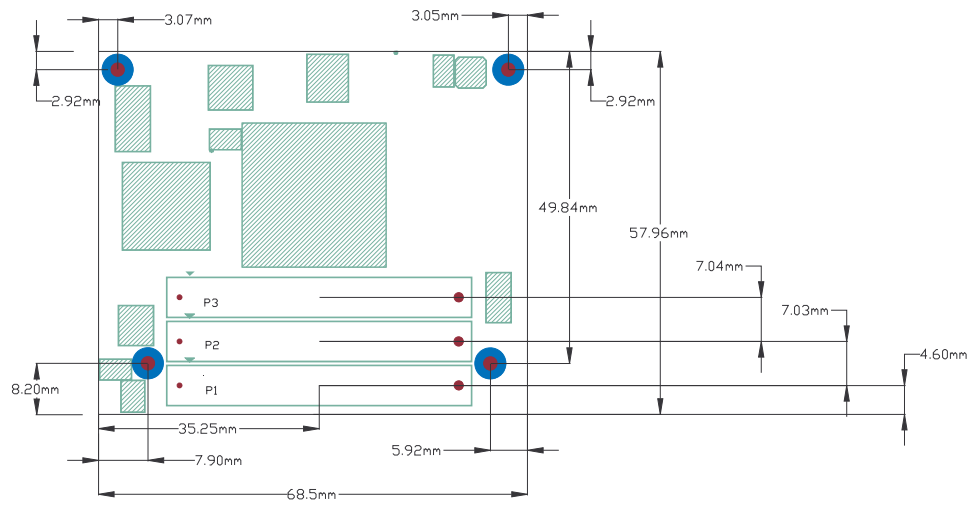

**Bottom side image, viewed from the top side of the module**

- The tolerance for all dimension is +/-0.05mm.
- Board-to-board mating height is 4.2 mm.
- Green hatched colored areas indicate height constraints - don't locate components beneath.
- Connectors' and mechanical layout is available in DXF format from CompuLab's website, following [Developer] >> [CM-iGLX] >> [CM-iGLX - Dimensions and Connectors Location] links.

### 4.3. Connectors Pinout

Note: gray-colored signals are not available. They are either not implemented or are routed through other pins of the connector (i.e., mixed with another function). Grayed signals are displayed in order to clarify standard CAMI pin assignment.

	<b>P1-A</b>		<b>P1-B</b>
P1-02	ETH1-RDN	P1-01	ETH1-TDP
P1-04	ETH1-RDP	P1-03	ETH1-TDN
P1-06	ETH1-LINK10#	P1-05	ETH1-LINK100#
P1-08	<b>GND</b>	P1-07	<b>VCORE</b>
P1-10	ETH1-ACT#	P1-09	WP1#
P1-12	SPARE	P1-11	RST-IN#
P1-14	<b>GND</b>	P1-13	GPIO6
P1-16	GPIO5	P1-15	GPIO27
P1-18	GPIO25	P1-17	PME#
P1-20	VCC-RTC	P1-19	<b>VCORE</b>
P1-22	COMA-RX	P1-21	SUSP-IN
P1-24	COMA-TX	P1-23	COMB-RX
P1-26	<b>GND</b>	P1-25	COMB-TX
P1-28	COMC-RX	P1-27	COMD-RX
P1-30	COMC-TX	P1-29	COMD-TX
P1-32	COMC-DCD#	P1-31	<b>VCC3-3</b>
P1-34	COMC-DTR#	P1-33	COMD-DCD#
P1-36	COMC-DSR#	P1-35	COMD-DTR#
P1-38	<b>GND</b>	P1-37	COMD-DSR#
P1-40	COMC-CTS#	P1-39	COMD-CTS#
P1-42	COMC-RTS#	P1-41	COMD-RTS#
P1-44	COMC-RIN#	P1-43	<b>VCORE</b>
P1-46	IDE-RD#	P1-45	COMD-RIN#
P1-48	IDE-WR#	P1-47	LB/IDE-CS0#
P1-50	<b>GND</b>	P1-49	IDE-IRQ
P1-52	LB/IDE-CS1#	P1-51	LB-IRQ0
P1-54	LB-IRQ1	P1-53	TS-PX
P1-56	DEBUG1	P1-55	<b>VCORE</b>
P1-58	DEBUG0	P1-57	TS-PY
P1-60	SSI-DOUT	P1-59	SSI-DIN
P1-62	<b>GND</b>	P1-61	SSI-CLK
P1-64	LB-A0	P1-63	LB-A1

P1-66	LB-A2
P1-68	LB-A4
P1-70	LB-A6
P1-72	LB-A8
P1-74	<b>GND</b>
P1-76	LB-A10
P1-78	LB-A12
P1-80	LB-A14
P1-82	LB-A16
P1-84	LB-A18
P1-86	<b>GND</b>
P1-88	LB-A20
P1-90	LB-A22
P1-92	LB-A24
P1-94	LB-D0
P1-96	LB-D2
P1-98	<b>GND</b>
P1-100	LB-D4
P1-102	LB-D6
P1-104	LB-D8
P1-106	LB-D10
P1-108	LB-D12
P1-110	<b>GND</b>
P1-112	LB-D14
P1-114	LB-IOCS16#
P1-116	LB-RD# (a)
P1-118	LB-WR# (b)
P1-120	PCM-MEMW# (d)
P1-122	<b>GND</b>
P1-124	PCM-CE1#
P1-126	PCM-CDA#
P1-128	PCM-INT0
P1-130	PCM-WE#
P1-132	PCM-SKTSEL
P1-134	<b>GND</b>
P1-136	USB3-P
P1-138	USB3-N
P1-140	<b>VCC5</b>

P1-65	LB-A3
P1-67	<b>VCC3-3</b>
P1-69	LB-A5
P1-71	LB-A7
P1-73	LB-A9
P1-75	LB-A11
P1-77	LB-A13
P1-79	<b>VCORE</b>
P1-81	LB-A15
P1-83	LB-A17
P1-85	LB-A19
P1-87	LB-A21
P1-89	LB-A23
P1-91	<b>VCORE</b>
P1-93	LB-A25
P1-95	LB-D1
P1-97	LB-D3
P1-99	LB-D5
P1-101	LB-D7
P1-103	<b>VCC3-3</b>
P1-105	LB-D9
P1-107	LB-D11
P1-109	LB-D13
P1-111	LB-D15
P1-113	LB-IORDY
P1-115	<b>VCORE</b>
P1-117	PCM-MEMR# (c )
P1-119	PCM-IOR# (e)
P1-121	PCM-IOW# (f)
P1-123	PCM-WAIT#
P1-125	PCM-RST#
P1-127	<b>VCORE</b>
P1-129	PCM-REG#
P1-131	PCM-CE2#
P1-133	LB-CS0#
P1-135	LB-CS1#
P1-137	RST-OUT#
P1-139	<b>VCC3-3</b>

	<b>P2-A</b>
P2-02	<b>GND</b>
P2-04	SPARE
P2-06	PCI-INTA#
P2-08	PCI-INTB#
P2-10	LPC-LAD0
P2-12	LPC-LAD2
P2-14	<b>GND</b>
P2-16	PCI-CLK0
P2-18	PCI-REQ1#
P2-20	PCI-AD0
P2-22	PCI-AD1
P2-24	PCI-AD3
P2-26	<b>GND</b>
P2-28	PCI-AD6
P2-30	PCI-CBE0#
P2-32	PCI-AD9
P2-34	PCI-AD10
P2-36	PCI-AD12
P2-38	<b>GND</b>
P2-40	PCI-AD15
P2-42	PCI-PAR
P2-44	PCI-PERR#
P2-46	PCI-STOP#
P2-48	PCI-TRDY#
P2-50	<b>GND</b>
P2-52	PCI-CBE2#
P2-54	PCI-AD17
P2-56	PCI-AD19
P2-58	PCI-AD20
P2-60	PCI-AD22
P2-62	<b>GND</b>
P2-64	PCI-AD24
P2-66	PCI-AD26
P2-68	PCI-AD28

	<b>P2-B</b>
P2-01	PCI-REQ0#
P2-03	PCI-GNT0#
P2-05	PCI-GNT1#
P2-07	<b>VCC3-3</b>
P2-09	LPC-LAD1
P2-11	LPC-LAD3
P2-13	LPC-SERIRQ
P2-15	LPC-LFRAME#
P2-17	LPC-LDRQ#
P2-19	<b>VCORE</b>
P2-21	PCI-AD2
P2-23	PCI-AD4
P2-25	PCI-AD5
P2-27	PCI-AD7
P2-29	PCI-AD8
P2-31	<b>VCORE</b>
P2-33	PCI-AD11
P2-35	PCI-AD13
P2-37	PCI-AD14
P2-39	PCI-CBE1#
P2-41	PCI-SERR#
P2-43	<b>VCC3-3</b>
P2-45	PCI-DEVSEL#
P2-47	PCI-IRDY#
P2-49	PCI-FRAME#
P2-51	PCI-AD16
P2-53	PCI-AD18
P2-55	<b>VCORE</b>
P2-57	PCI-AD21
P2-59	PCI-AD23
P2-61	PCI-CBE3#
P2-63	PCI-AD25
P2-65	PCI-AD27
P2-67	<b>VCORE</b>

P2-70	PCI-AD29
P2-72	PCI-AD31
P2-74	<b>GND</b>
P2-76	PP-PD3
P2-78	PP-PD4
P2-80	PP-PD5
P2-82	PP-PD6
P2-84	PP-PD7
P2-86	<b>GND</b>
P2-88	PP-ACK#
P2-90	PP-BUSY
P2-92	PP-PE
P2-94	PP-SLCT
P2-96	LCD-LP
P2-98	<b>GND</b>
P2-100	LCD-B3
P2-102	LCD-B5
P2-104	LCD-G1
P2-106	LCD-G2
P2-108	LCD-G4
P2-110	<b>GND</b>
P2-112	LCD-SCK
P2-114	LCD-DE-M
P2-116	LCD-R3
P2-118	LCD-R4
P2-120	PS2-KCLK
P2-122	<b>GND</b>
P2-124	PS2-MDAT
P2-126	PS2-MCLK
P2-128	PCM-INT-RDYB
P2-130	AUD-INR
P2-132	AUD-INL-MIC
P2-134	<b>GND</b>
P2-136	AUD-OUTR
P2-138	USB1-P
P2-140	USB1-N

P2-69	PCI-AD30
P2-71	TS-MX
P2-73	TS-MY
P2-75	PP-PD2
P2-77	PP-PD1
P2-79	<b>VCC3-3</b>
P2-81	PP-PD0
P2-83	PP-STROBE#
P2-85	PP-ALF#
P2-87	PP-ERROR#
P2-89	PP-INIT#
P2-91	<b>VCORE</b>
P2-93	PP-SLCTIN#
P2-95	LCD-B1
P2-97	LCD-B2
P2-99	LCD-B4
P2-101	LCD-G0
P2-103	<b>VCORE</b>
P2-105	LCD-G3
P2-107	LCD-G5
P2-109	LCD-R1
P2-111	LCD-FRM
P2-113	LCD-R2
P2-115	<b>VCORE</b>
P2-117	LCD-R5
P2-119	PS2-KDAT
P2-121	IRDA-TX
P2-123	IRDA-RX
P2-125	PCM-CDB#
P2-127	<b>VCORE</b>
P2-129	AUD-SPDIF
P2-131	AUD-OUTL
P2-133	USB-OVC#
P2-135	<b>VCC3-3</b>
P2-137	USB2-P
P2-139	USB2-N

	P3-A		P3-B
P3-02	ETH2-RDP	P3-01	ETH2-TDN
P3-04	ETH2-RDN	P3-03	ETH2-TDP
P3-06	ETH2-LINK10#	P3-05	ETH2-LINK100#
P3-08	<b>GND</b>	P3-07	<b>VCORE</b>
P3-10	ETH2-ACT#	P3-09	SPARE
P3-12	SPARE	P3-11	SPARE
P3-14	<b>GND</b>	P3-13	PCI-REQ3#
P3-16	PCI-CLK1	P3-15	PCI-GNT3#
P3-18	PCI-GNT2#	P3-17	PCI-INTD#
P3-20	PCI-INTC#	P3-19	<b>VCC3-3</b>
P3-22	PCI-REQ2#	P3-21	COMA-DCD#
P3-24	PCI-CLK2	P3-23	COMA-DTR#
P3-26	<b>GND</b>	P3-25	COMA-DSR#
P3-28	COMA-RTS#	P3-27	COMA-CTS#
P3-30	COMA-RIN#	P3-29	COMB-DCD#
P3-32	COMB-RTS#	P3-31	<b>VCORE</b>
P3-34	COMB-RIN#	P3-33	COMB-CTS#
P3-36	COMB-DTR#	P3-35	COMB-DSR#
P3-38	<b>GND</b>	P3-37	GPIO4
P3-40	GPIO5	P3-39	GPIO6
P3-42	GPIO7	P3-41	GPIO8
P3-44	GPIO9	P3-43	<b>VCORE</b>
P3-46	GPIO10	P3-45	GPIO11
P3-48	GPIO12	P3-47	GPIO13
P3-50	<b>GND</b>	P3-49	GPIO14
P3-52	GPIO15	P3-51	FW-TPBM
P3-54	GPIO16	P3-53	FW-TPBP
P3-56	GPIO17	P3-55	<b>VCC3-3</b>
P3-58	GPIO18	P3-57	FW-TPAP
P3-60	GPIO19	P3-59	FW-TPAM
P3-62	<b>GND</b>	P3-61	TIMER-OUT
P3-64	TIMER-START	P3-63	IDE-DREQ
P3-66	IDE-RDY#	P3-65	IDE-DACK#
P3-68	LB-CS2#	P3-67	<b>VCORE</b>

P3-70	LB-CS3#	P3-69	LB-DREQ0
P3-72	CLKIN	P3-71	LB-DACK0#
P3-74	<b>GND</b>	P3-73	LB-DREQ1
P3-76	CLKOUT	P3-75	LB-DACK1#
P3-78	VIP-CS	P3-77	JTAG-TCK
P3-80	VIP-D0	P3-79	<b>VCORE</b>
P3-82	VIP-D1	P3-81	JTAG-TMS
P3-84	VIP-D2	P3-83	JTAG-TDI
P3-86	<b>GND</b>	P3-85	JTAG-TDO
P3-88	VIP-CLK	P3-87	JTAG-TRST#
P3-90	VIP-D3	P3-89	VIP-D7
P3-92	VIP-D4	P3-91	<b>VCC3-3</b>
P3-94	VIP-D5	P3-93	VIP-ODD/EVEN
P3-96	VIP-D6	P3-95	SLEEP-OUT#
P3-98	<b>GND</b>	P3-97	SPARE
P3-100	WP2#	P3-99	<b>VCC5-STBY</b>
P3-102	VCC3-STBY	P3-101	SPARE
P3-104	VCC3-STBY	P3-103	<b>VCORE</b>
P3-106	VCC3-STBY	P3-105	SPARE
P3-108	SPARE	P3-107	VCC3-STBY
P3-110	<b>GND</b>	P3-109	VCC3-STBY
P3-112	SPARE	P3-111	VCC3-STBY
P3-114	PCM-BVD1	P3-113	PCM-BVD2
P3-116	PCM-VPPEN	P3-115	<b>VCORE</b>
P3-118	PCM-CE#	P3-117	PCM-VCCEN
P3-120	AC97-BITCLK	P3-119	AC97-SDIN0
P3-122	<b>GND</b>	P3-121	AC97-SDIN1
P3-124	AC97-RST#	P3-123	AC97-SDOUT
P3-126	LCD-B0	P3-125	AC97-SYNC
P3-128	LCD-R0	P3-127	<b>VCC3-3</b>
P3-130	LCD-VDDEN	P3-129	CRT-HSYNC
P3-132	CRT-R	P3-131	<b>VCC5</b>
P3-134	<b>GND</b>	P3-133	CRT-B
P3-136	CRT-G	P3-135	<b>VCC3-3</b>
P3-138	TV-OUT	P3-137	USB4-P
P3-140	CRT-VSYNC	P3-139	USB4-N

## 5. MEMORY and I/O mapping

### 5.1. Memory space usage in the first 1MB

0000:0 - 9FFF:F	Standard Low memory
A000:0 - BFFF:F	Graphic Memory Available if graphics controller is not enabled
C000:0 - C7FF:F	VGA BIOS
DC00:0 - DFFF:F	SMM reserved area
E000:0 - FFFF:F	BIOS

### 5.2. Memory space usage above first 1MB

0x00100000	SDRAM
0x0EBE4BFF	
0x0EBE5C00	ACPI Manager
0x0EBE8C00	
0x0EBE9000	Firmware
0x0EFFFFFF	
0x0F000000	Frame Buffer
0x0FFFFFFF	
0x10000000	PCI memory space
0xFFEFFFFFFF	
0xFFF00000	
0xFFFFFFFF	BIOS

The “Frame Buffer” cannot be accessed directly, this address space is left unused in the system; above table includes a 16Mb “Frame buffer”(can vary from 2- 128Mb)

### 5.3. I/O space Usage

The table below specifies all I/O regions known to be used in standard / legacy PC architecture and regions used by on-board peripheral devices.

Address	Function	Comments
0x000-0x00F	Slave DMA regs	
0x020-0x021	Master Interrupt controller	
0x040-0x043	PIT registers	
0x060-0x060	Keyboard / PS2 mouse registers	
0x061-0x061	System speaker	
0x064-0x064	Keyboard / PS2 mouse registers	
0x070-0x071	System CMOS/real time clock	
0x081-0x083	DMA controller registers	
0x084-0x086	General purpose IO register	
0x087	DMA controller registers	
0x088	General purpose IO register	
0x089-0x08B	DMA controller registers	
0x08F-0x091	DMA controller registers	
0x0A0-0x0A1	Slave interrupt controller registers	
0x0F0-0x0FF	Numeric Data Processor	
0x1F0-0x1F7	IDE0 controller	
0x2F8-0x2FF	COM-B	
0x3B0-0x3DF	Legacy VGA base	
0x3E0-0x3E1	PCMCIA / CardBus	
0x3F8-0x3FF	COM-A	
0x3F0-0x3F7	alternate IDE0 address	
0xCF8-0xCFF	PCI configuration space access window	
0xD400-0xD47F	Geode LX Audio driver	
0xD800-0xD80F	PCI IDE controller	
0xF400-0xF4FF	Core Ethernet controller	
0xF800-0xF8FF	Base Ethernet controller	

## 5.4. BIOS Flash Mapping

Starting address in flash window	End address in flash window	Usage
0xFFFF8000	0xFFFF0000	BIOS area
0xFFFFD000	0xFFFFE000	Setup and configuration block
0xFFFFFC000	0xFFFFF0000	BIOS area

### Setup and Configuration Block Usage

Addresses	Value / Description
0x0000-0x0001	0xAAAA –signature that a valid CMOS image is in the flash
0x0002-0x01FF	CMOS image, including RTC

## 6. Power Consumption

The current consumption measurements specified below were performed on a system with the following configuration:

- CM-iGLX-D256-C500-N512-E-AT
- ATX-E-L-V-A-C3-X6-Y2-Z6

Current consumption is specified for both boards. However, 95% of the total current is consumed by the CM-iGLX module.

CPU Clock	Activity	Current from 3.3V
200 MHz	Idle	0.98A
	Max load	1.04A
500 MHz	Idle	1.26A
	Max load	1.51A

Minimum power consumption :  $[3.3V * 0.98A] = 3.25$  watt

Maximum power consumption :  $[3.3V * 1.51A] = 5.0$  watt

## 7. Performance Benchmarks

Measured with CPU @ 500 MHz, using SiSoft Sandra bench test under Windows.

Drystone (integer)	990 MIPS
Wetstone (floating point)	270 MFLOPS
DDR bandwidth	557MB/s

## 8. Operating Temperature Ranges

The CM-iGLX is available with three options for operating temperature range:

<b>Range</b>	<b>Temp.</b>	<b>Description</b>
Commercial	0° to 70° C	Sample cards from each batch are tested for the lower and upper temperature limits. Individual cards are not tested.
Extended	-20° to 70° C	Every card is individually tested for the lower limit (-20° C) qualification.
Industrial	-40° to 85° C	Every card is individually tested for both lower and upper limits and at several midpoints.

\* Temp - maximum temperature measured on hottest spot of the card - CPU case.

For more information regarding the availability of cards for industrial grade, please refer to [Products] >> [Industrial Temperature] links in CompuLab's website.

### Heat Dissipation

Heatsink is not mandatory for CM-iGLX operation, however it does affect the CM-iGLX's working condition. In still air CPU temperature can rise up to 35°C above ambient. For example, at a room temperature of 25°C, a powered card without heatsink will reach 60°C, which is just 10°C below the upper limit. Still air and absence of heatsink are therefore limiting maximum allowed ambient temperature. If you need wider operation range, you should consider using forced airflow and/or heatsink.