

Smart actuator module for legged robots

AI MOTOR-601 MANUAL

Ver 1.25



Thank you for your purchasing our product. This manual shows how to use AI MOTOR-601 very neatly. Before using your AI MOTOR-601, please read this manual carefully.



MEGAROBOTICS LTD.
www.megarobotics.com

CONTENTS

1. Introduction	
1.1. Summary	3
1.2. Package contents	3
1.3. Names of parts	4
1.4. Functions	5
1.5. Features and specifications	6
2. Detailed Description and Usage	
2.1. Hardware interface	8
2.2. Mechanical interface	11
2.3. Software interface	13
2.4. Position control function	20
3. Appendix	
3.1. RS-232 board	21
3.2. Application examples of AI MOTOR	22

1. INTRODUCTION

1.1. Summary

AI MOTOR-601 is an actuator module for legged robots that can assemble and control various types of robots. Motors are essential for all the moving devices. However, it is not available for general people since special devices and a lot of money are required in control, electronic circuit, and connection and combination of parts. AI MOTOR-601 integrates motors, members and control circuits in one module so as to easily connect them to one another. Accordingly, if you use the product, you can design joints of a moving device simply and it is easy to expand the device additionally and to cope with troubles of the device. It is possible to connect motors to each other serially so as to simplify wiring. Control commands can be delivered once through a widely used RS-232 serial communication. Operation of motors can be monitored since AI MOTOR-601 has a function of outputting the amount of the current flowing in the motor and position of the motor.

The operation modes are 360 degrees rotation mode, 0 to 332 degrees range position control mode, act down mode in which position change of the shaft of the motor can be monitored using external force by making torque of the shaft of the motor be zero, and power down mode in which power consumption is minimized.

The internal parameters of the motor can be changed by a program through serial communication. The changeable parameters are ID of the motor, baud-rate of the serial communication, position control resolution, position control gain, threshold of over-current. AI MOTOR-601 internally confirms external power and controls internal control gain automatically so that constant control response is ensured though input voltage varies. It protects the motor against being damaged by cut off the motor current automatically when the current flowing in the motor is too much, where the threshold of over-current can be changed.

11 types of connecting parts are provided so as to assemble parts in various directions when connecting motors to each other. And also, since there are two shafts of the motor, it is very convenient to connect joints.

1.2. Package Contents

- ① AI MOTOR
- ② Cable
- ③ Joint parts (11 pieces)
- ④ Bolt M1.8 × 8 mm
 - Bolts M2.0 × 12 mm (2 pieces)
 - Bolts M2.0 × 16 mm (2 pieces)
 - Nuts M2.0 (4 pieces)
- ⑤ Spare gear 2
 - Spare gear 3

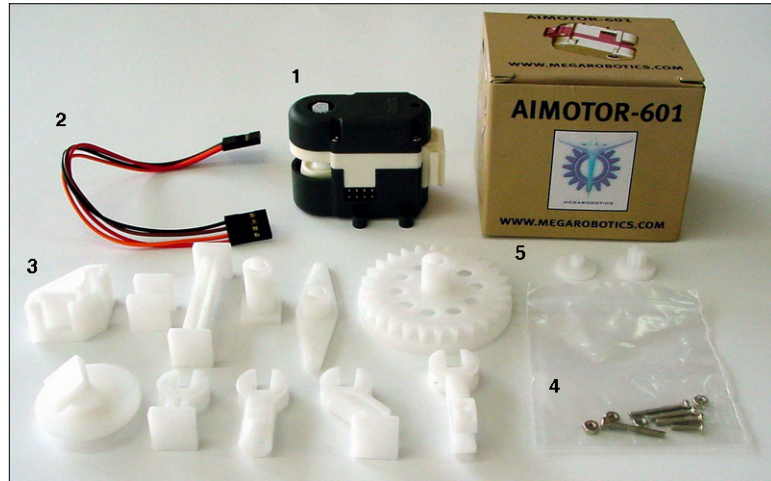

Figure 1. Package contents

1.3. Names of Parts

Disassembled view of body

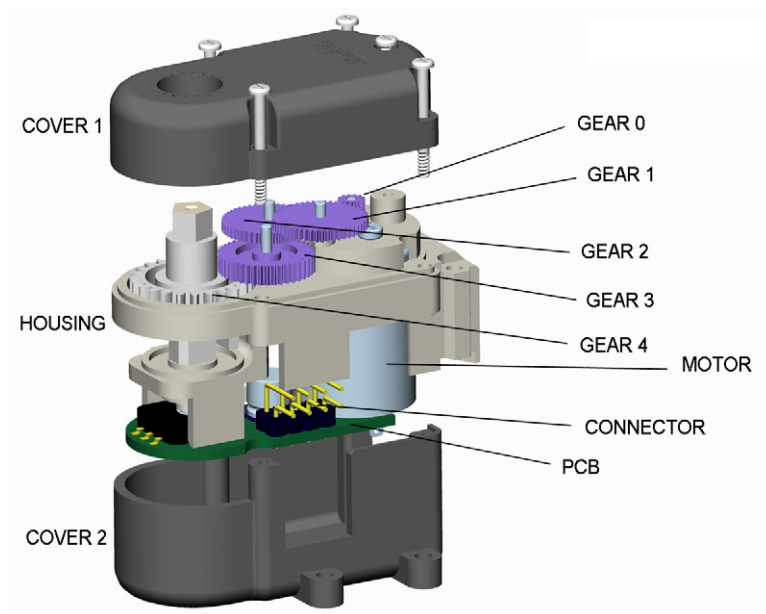

Figure 2. Disassembled view of body

Joint parts

Table 1. Usage of Joints

Usage	Joint part number
Shaft ↔ Body connection	1, 3, 6
Shaft ↔ Shaft connection	2, 10
Body ↔ Body connection	4, 8
Miscellaneous connection	5, 7, 9, 11

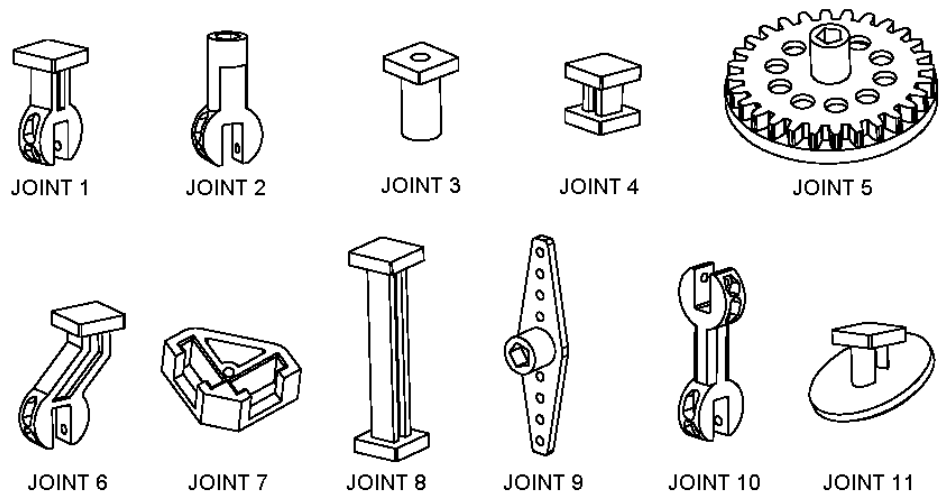

Figure 3. 11 types of Joints

Cable

Cable to connect motors to each other or connect a motor to a control board. Length is 15 cm.

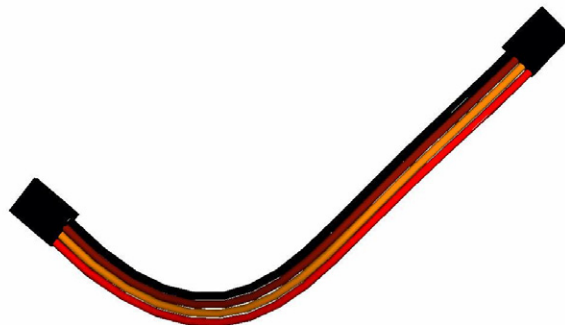

Figure 4. Cable

1.4. Functions

Position control function

Low resolution mode (0 to 332 degrees), High resolution mode (0 to 166 degrees)

Sensor function

Feedback of Current (8 bit) and Position (8 bit)

Speed control function

Position send mode 5 steps, 360 degrees rotation mode 16 steps

Resolution adjustment function (2 steps)

Low resolution 1.3 degrees, High resolution 0.65 degree

360 degrees rotation function (wheel operation mode)

Reverse voltage protection

0 to -28 V

Over-current protection

Settable range 400 to 1000 mA

Parameter setting function

ID, Baud-rate, resolution, threshold of over-current, P-gain, D-gain

Voltage sensing function

Internal control gain is set automatically depending on Input voltage
(DC 5 to 10 V)

Mechanical direct connection between modules

Various connections are possible using 2 output shafts, body joint part and 11 types of joint parts.

Electrical direct connection between modules

Electrical direct connection are possible using two connector terminals and a connector cable.

Control signal I/O by communication

A full-duplex UART is built-in. The motors are controlled in RS-232 serial communication. 31 motors can be connected and controlled in one channel

1.5. Features and specifications

Advantages

- High performance to price
- Excellent assembly between motors
- Good gear endurance
- Various operation modes supplied
- Test tool program supplied
- Various application program supplied

Size

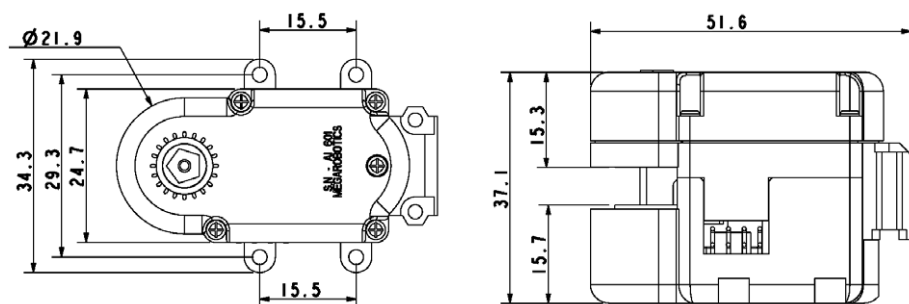

Figure 5. Size of Body

unit : mm

Specifications

Table 2. Specifications of AI MOTOR-601

Communication	Standards		RS-232 asynchronous serial communication (TTL level)
	Capability of Connection		Maximum 31 per one communication channel
Parameter Range	ID		0 to 30
	Baud-rate		2400 to 460800 bps
	Resolution		Low Resolution (1.3 degrees) or High Resolution (0.65 degree)
	P-Gain		Recommended 1 to 50
	D-Gain		Recommended 1 to 100
	Threshold of Over-current		Approximate 400 mA to 1000 mA
Operation	Maximum Torque		Approximate 6 Kg·cm (at +9.5 V)
	Maximum Speed		90 rpm (at +9.5 V)
	Minimum Angle		Low resolution mode : $333.3/255 \approx 1.307$ degrees High resolution mode : $166.65/255 \approx 0.654$ degree
Operation Mode	Position Send Mode	Speed Mode 0 (Max.)	The present current and position are informed of and it moves to a specific position
		Speed Mode 1	
		Speed Mode 2	
		Speed Mode 3	
		Speed Mode 4 (Min.)	
	Position Read Mode		The present current and position are informed of.
	Act Down Mode (Position Sensor Mode)		The present current and position are informed of, torque of the motor is removed, and the motor is moved by the external force.
	Power Down Mode		Power down state is maintained without torque of the motor until another command is received.
360 degrees Rotation Mode		16 steps speed control(0: stop, 1: min, 15: max)	
System Protection	Limitation of Over-current		Approximate 400 to 1000 mA (settable by user)
	Inverse Voltage Protection		0 to -28 V
Electrical	Motor	Types	DC precious metal brush motor
		Maximum Current	650 mA at DC 5V, 1000 mA at DC 10 V
	Control Circuit	Input Voltage Level	High (2.8 to 5.2 V), Low (-1.0 to 1.41 V)
		Output Voltage Level	High (3.25 to 4.7 V), Low (0 to 0.6 V)
Current		10 mA in general mode, 4.5 mA in power down mode	
Mechanical	Connecting Parts		11 types (Plastic)
	Size(Max.)		51.6 × 34.3 × 37.1 mm
	Weight		40 g
	Mutual Connecting Points		3 places
	Gear Ratio		1 / 160
	Gear Material		Plastic

Block diagram

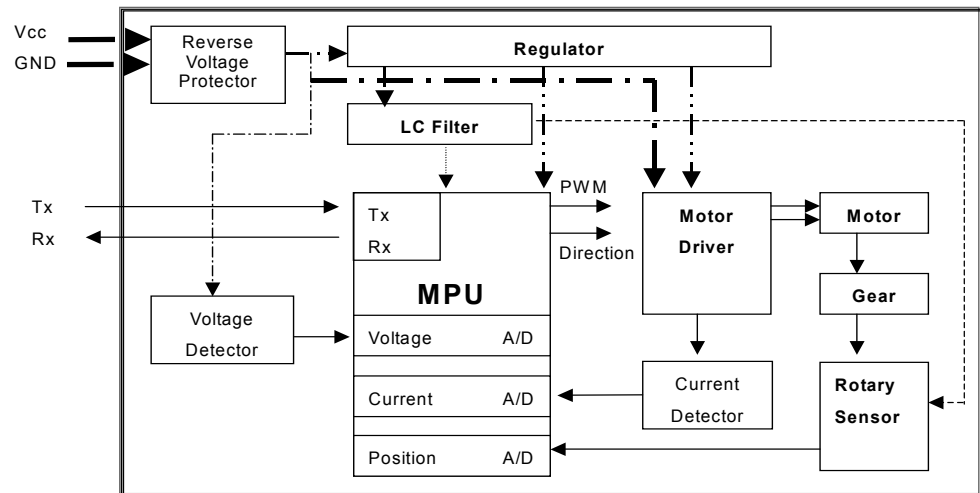

Figure 6. Block diagram of AI MOTOR-601

2. Detailed Description and Usage

2.1. Hardware interface

Power supply and signal line used in a connector that is hardware interface of AI MOTOR will be described from now on.

Connector

AI MOTOR body has two connectors. Two connectors are connected to each other in parallel internally. You can use AI MOTOR if you connect any one of the two connectors. The other connector is used to connect another module in serial. Take precaution on pin arrangement when you insert the connector. If you insert the joint part wrongly, the device does not operate. However, the device is not out of order owing to inverse voltage protection function.

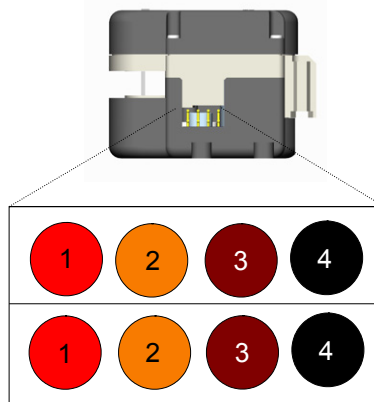

1: Vcc, 2: TXD of AI MOTOR, 3: RXD of AI MOTOR, 4: Ground

Figure 7. Connector

Electrical characteristics

Table 3. Maximum Operating Conditions

Symbol	Parameter	Min.	Max.	Unit
V _{CC}	Supply Voltage	4.5	10.5	V
I _{CC}	Operation Current	4.5	1010	mA
V _{IL}	Input Low Voltage	-1.0	1.4	V
V _{IH}	Input High Voltage	2.8	5.2	V
V _{OL}	Output Low Voltage	0	0.6	V
V _{OH}	Output High Voltage	3.25	4.7	V
T _O	Operating Temperature	0	70	°C
T _S	Storage Temperature	-40	120	°C

Table 4. Recommended Operating Conditions

Symbol	Parameter	Min.	Max.	Unit
V _{CC}	Supply Voltage	5.5	9	V
I _{CC}	Operation Current	5.5	600	mA
V _{IL}	Input Low Voltage	-0.5	1.2	V
V _{IH}	Input High Voltage	3.29	5.2	V
V _{OL}	Output Low Voltage	0	0.6	V
V _{OH}	Output High Voltage	4.0	4.7	V
T _O	Operating Temperature	10	40	°C
T _S	Storage Temperature	-40	80	°C

Power On Reset

No commands are received for 64 ms after turned on. After that, operating in act down mode.

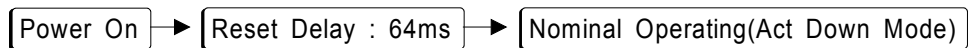

Figure 8. Sequence of Power On Reset

RS-232 signal timing

Control commands and data are transmitted and received in asynchronous RS-232 communication of TTL level.

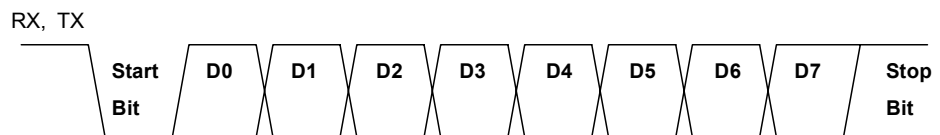

Figure 9. Signal Timing of RS-232 communication

RS-232 communication delay

Since AI MOTOR-601 receives commands in RS-232 communication, all the motors do not receive commands at the same time in the case that a few modules are connected and the motors are controlled. Although communication delay is usually negligible, consider communication delay time shown in the following table and use AI MOTOR-601.

Table 5. Delay Time of Communication

Baud-rate (bps)	1 byte transmission time (ms)	1 command (4 bytes) transmission time (ms)	1 command delay angle (Deg.) at 30 rpm
2400	4.167	16.667	3
4800	2.083	8.333	1.5
9600	1.042	4.167	0.75
19200	0.521	2.083	0.375
38400	0.260	1.042	0.1875
57600	0.174	0.694	0.0125
115200	0.087	0.347	0.0625
153600	0.065	0.260	0.046875
230400	0.043	0.174	0.03125
460800	0.022	0.087	0.015625

Position control response

Since control gain is set automatically owing to automatic voltage sensing function, it does not over-shoot though input voltage is raised up.

※ Conditions of Experiment

- Initial position : 15
- Target position : 165
- Load : 0
- Measuring time : 2 seconds
- Number of samples : 80

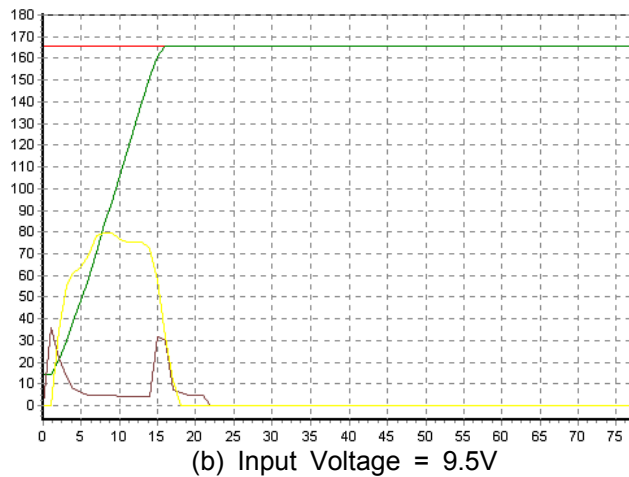
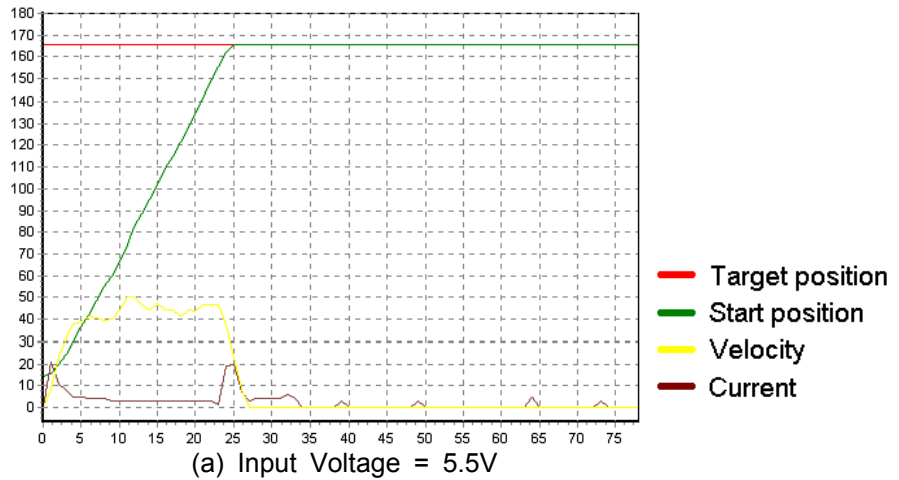



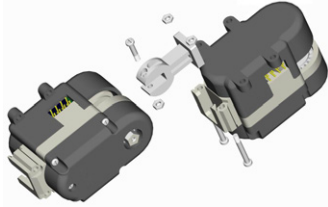
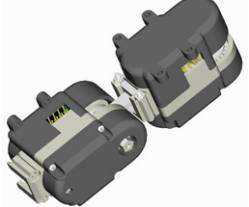

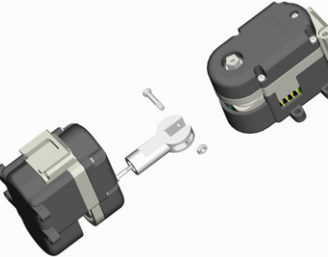
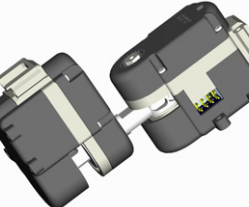

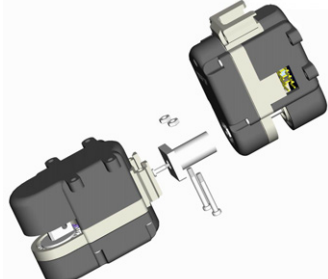
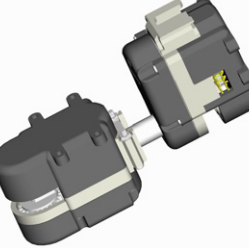

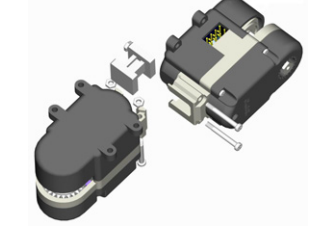
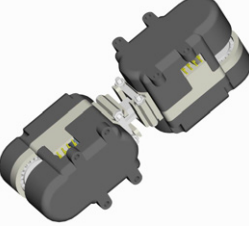

Figure 10. Response of Position Send Command







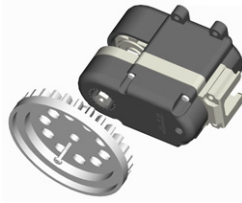
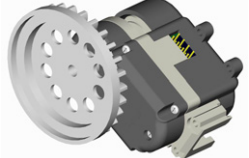

2.2. Mechanical interface

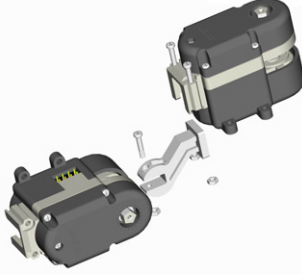
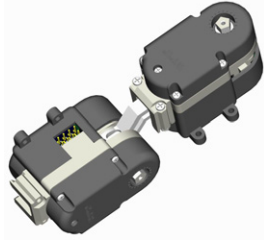
The usage of a body joint part, an output shaft and a joint part which are mechanical parts of AI MOTOR will be taught.

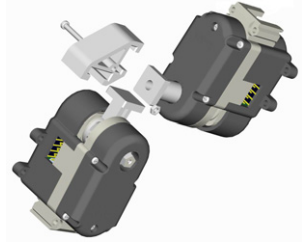
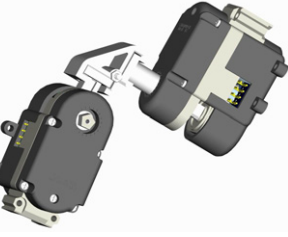
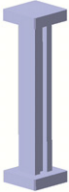
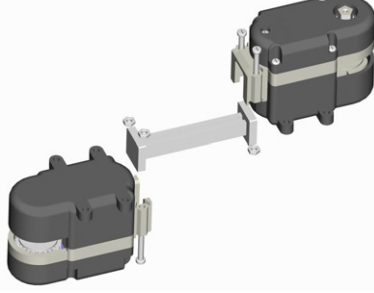
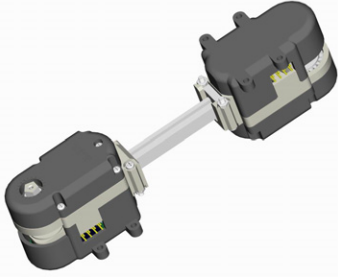
Types and examples of joint parts

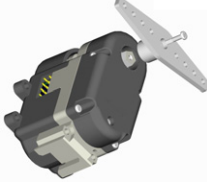
Table 6. Usage of Joints

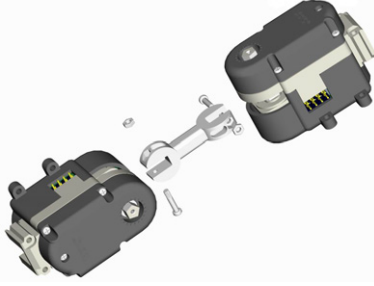
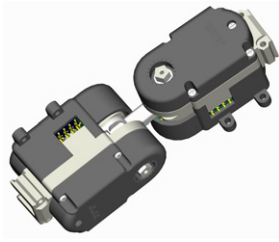
Joint parts	Assembly forms	Assembled appearances
 <p>JOINT 1</p>		
 <p>JOINT 2</p>		
 <p>JOINT 3</p>		
 <p>JOINT 4</p>		
 <p>JOINT 5</p>		

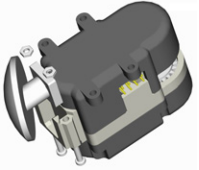
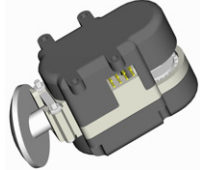
Joint parts	Assembly forms	Assembled appearances
 <p data-bbox="544 423 654 454">JOINT 6</p>		
 <p data-bbox="544 701 654 732">JOINT 7</p>		
 <p data-bbox="544 1070 654 1102">JOINT 8</p>		
 <p data-bbox="544 1373 654 1404">JOINT 9</p>		
 <p data-bbox="536 1659 663 1691">JOINT 10</p>		
 <p data-bbox="536 1921 663 1953">JOINT 11</p>		

2.3. Software interface

Communication protocol that is software interface of AI MOTOR will be described.

2.3.1. Communication flow

All the communication commands flow as illustrated in the following figure. When a controller sends a command packet to AI MOTOR, AI MOTOR returns a response packet to the controller.

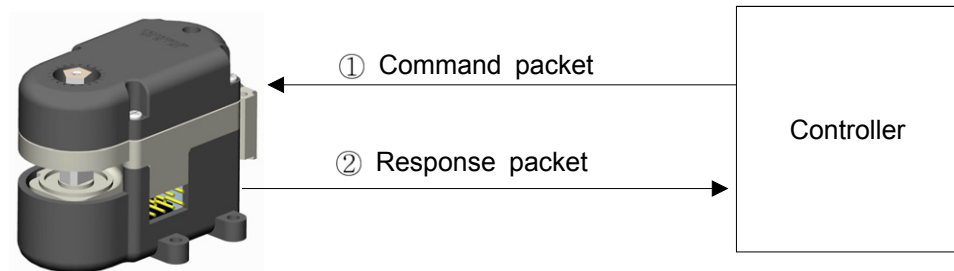

Figure 11. Flow of Communication

2.3.2. Command Packet

There are two kinds of command packets, that is, an operation command packet (4 bytes) and a setting command packet (6 bytes).

2.3.2.1. Operation Command Packet (4 bytes)

Position Send Command

Command to return the present current of AI MOTOR and the present position of output shaft, and move to a desired location. The speed can be controlled in 5 levels.

► Command Packet

1byte	1byte	1byte	1byte
Header	Data1	Data2	Checksum

- Header = 0xFF(Packet start)

- Data1 =

Speed			ID				
7	6	5	4	3	2	1	0

} bit number

※ Speed : 0(max)~4(min)
ID : 0~30

- Data2 = 0~254(Position)

- Checksum = (Data1 XOR Data2) AND 0x7F

► Response Packet

1 byte	1 byte
Current	Position

- Current = approximate 18.4 mA per 1

- Position = 0~255

Position Read Command

Command to return the present current of AI MOTOR and the present position of output shaft

► Command Packet

1byte	1byte	1byte	1byte
Header	Data1	Data2	Checksum

- Header = 0xFF(Packet start)

- Data1 =

5 (=0b101)					ID			
7	6	5	4	3	2	1	0	

 bit number
 ※ ID : 0~30

- Data2 = arbitrary

- Checksum = (Data1 XOR Data2) AND 0x7F

► Response Packet

1 byte	1 byte
Current	Position

- Current = approximate 18.4 mA per 1

- Position = 0~255

Act Down Mode Command

Command to send the present position of output shaft and remove torque of the motor to move due to external force.

► Command Packet

1byte	1byte	1byte	1byte
Header	Data1	Data2	Checksum

- Header = 0xFF(Packet start)

- Data1 =

6 (=0b110)						ID	
7	6	5	4	3	2	1	0

 bit number
 ※ ID : 0~30

- Data2 =

1 (=0b0001)				Arbitrary			
7	6	5	4	3	2	1	0

 bit number

- Checksum = (Data1 XOR Data2) AND 0x7F

► Response Packet

1 byte	1 byte
Data2	Position

- Position = 0~255

Power Down Command

All the connected AI MOTORS are powered down. If a communication command is received, AI MOTORS are awakened.

Command to send the present position of output shaft and remove torque of the motor to move due to external force.

▶ Command Packet

1byte	1byte	1byte	1byte
Header	Data1	Data2	Checksum

- Header = 0xFF(Packet start)

- Data1 =

6 (=0b110)			31 (=0b11111)				
7	6	5	4	3	2	1	0

 bit number

- Data2 =

2 (=0b0010)				Arbitrary			
7	6	5	4	3	2	1	0

 bit number

- Checksum = (Data1 XOR Data2) AND 0x7F

▶ Response Packet

1 byte	1 byte
Don't care	Don't care

360 degrees Rotation Command

Command to rotate the shaft of AI MOTOR by 360 degrees. Its speed can be controlled in 16 levels.

▶ Command Packet

1byte	1byte	1byte	1byte
Header	Data1	Data2	Checksum

- Header = 0xFF(Packet start)

- Data1 =

6 (=0b110)			ID				
7	6	5	4	3	2	1	0

 bit number

※ ID : 0~30

- Data2 =

Direction				Speed			
7	6	5	4	3	2	1	0

 bit number

※ Direction : 3(CCW), 4(CW)

Speed : 0(stop), 1(min)~15(max)

- Checksum = (Data1 XOR Data2) AND 0x7F

▶ Response Packet

1 byte	1 byte
Rotations	Position

- Rotations = 0~255(rotations after power-on, ⊕ : CCW, ⊖ : CW)

- Position = 0~255

2.3.2.2. Setting command packet (6 bytes)

Baud-rate Set Command

Command to set the Baud-rate of AI MOTOR. Supplied Baud-rate is 2400, 4800, 9600, 19200, 38400, 57600, 115200, 230400, 307200 and 460800 bps.

▶ Command packet

1byte	1byte	1byte	1byte	1byte	1byte
Header	Data1	Data2	Data3	Data4	Checksum

- Header = 0xFF(Packet start)

- Data1 =

7 (=0b111)			ID					
7	6	5	4	3	2	1	0	

 bit number

※ ID : 0~30

- Data2 = 0x08

- Data3 = 0(460800bps), 1(230400bps), 2(153600bps), 3(115200bps), 7(57600bps), 11(38400bps), 23(19200bps), 47(9600bps), 95(4800bps), 191(2400bps)

- Data4 = Data3

- Checksum = (Data1 XOR Data2 XOR Data3 XOR Data4) AND 0x7F

▶ Response packet

1 byte	1 byte
New Baud-rate	New Baud-rate

- New Baud-rate = 0~191

Control Gain Set Command

Command to set the control gains of AI MOTOR. The settable control gains are proportional gain and differentiating gain.

▶ Command packet

1byte	1byte	1byte	1byte	1byte	1byte
Header	Data1	Data2	Data3	Data4	Checksum

- Header = 0xFF(Packet start)

- Data1 =

7 (=0b111)			ID					
7	6	5	4	3	2	1	0	

 bit number

※ ID : 0~30

- Data2 = 0x09

- Data3 = recommended 1~50(New P-gain)

- Data4 = recommended 1~100(New D-gain)

- Checksum = (Data1 XOR Data2 XOR Data3 XOR Data4) AND 0x7F

▶ Response packet

1 byte	1 byte
New P-gain	New D-gain

- New P-gain = 1~50

- New D-gain = 1~100

ID Set Command

Command to set the ID of AI MOTOR.

▶ Command packet

1byte	1byte	1byte	1byte	1byte	1byte
Header	Data1	Data2	Data3	Data4	Checksum

- Header = 0xFF(Packet start)

- Data1 =

7 (=0b111)			ID				
7	6	5	4	3	2	1	0

 bit number

※ ID : 0~30

- Data2 = 0x0A

- Data3 = 0~30(New ID)

- Data4 = Data3

- Checksum = (Data1 XOR Data2 XOR Data3 XOR Data4) AND 0x7F

▶ Response packet

1 byte	1 byte
New ID	New ID

- New ID = 0~30

Control Gain Read Command

Command to read the control gain of AI MOTOR.

▶ Command packet

1byte	1byte	1byte	1byte	1byte	1byte
Header	Data1	Data2	Data3	Data4	Checksum

- Header = 0xFF(Packet start)

- Data1 =

7 (=0b111)			ID				
7	6	5	4	3	2	1	0

 bit number

※ ID : 0~30

- Data2 = 0x0C

- Data3 = arbitrary

- Data4 = arbitrary

- Checksum = (Data1 XOR Data2 XOR Data3 XOR Data4) AND 0x7F

▶ Response packet

1 byte	1 byte
P-gain	D-gain

- P-gain = 1~50

- D-gain = 1~100

Resolution Set Command

Command to set the resolution of AI MOTOR.

▶ Command packet

1byte	1byte	1byte	1byte	1byte	1byte
Header	Data1	Data2	Data3	Data4	Checksum

- Header = 0xFF(Packet start)

- Data1 =

7 (=0b111)			ID					
7	6	5	4	3	2	1	0	bit number

※ ID : 0~30

- Data2 = 0x0D

- Data3 = 0(Low resolution), 1(High resolution)

- Data4 = Data3

- Checksum = (Data1 XOR Data2 XOR Data3 XOR Data4) AND 0x7F

▶ Response packet

1 byte	1 byte
New Resolution	New Resolution

- New Resolution = 0(Low resolution), 1(High resolution)

Resolution Read Command

Command to read the resolution of AI MOTOR.

▶ Command packet

1byte	1byte	1byte	1byte	1byte	1byte
Header	Data1	Data2	Data3	Data4	Checksum

- Header = 0xFF(Packet start)

- Data1 =

7 (=0b111)			ID					
7	6	5	4	3	2	1	0	bit number

※ ID : 0~30

- Data2 = 0x0E

- Data3 = arbitrary

- Data4 = arbitrary

- Checksum = (Data1 XOR Data2 XOR Data3 XOR Data4) AND 0x7F

▶ Response packet

1 byte	1 byte
Resolution	Resolution

- Resolution = 0(Low resolution), 1(High resolution)

Threshold of Over-Current Set Command

Command to set the threshold of over-current of AI MOTOR.

▶ Command packet

1byte	1byte	1byte	1byte	1byte	1byte
Header	Data1	Data2	Data3	Data4	Checksum

- Header = 0xFF(Packet start)

- Data1 =

7 (=0b111)			ID					
7	6	5	4	3	2	1	0	

 bit number

※ ID : 0~30

- Data2 = 0x0F

- Data3 = 22~54 (=Coefficient × threshold of over-current in mA)
ex) 22 ≙ 0.054468085 × 403.9 mA

- Data4 = Data3

- Checksum = (Data1 XOR Data2 XOR Data3 XOR Data4) AND 0x7F

▶ Response packet

1 byte	1 byte
New Threshold of Over-current	New Threshold of Over-current

- New Threshold of Over-current

= 22~54 (=Coefficient × threshold of over-current in mA)

Threshold of Over-Current Read Command

Command to read the threshold of over-current of AI MOTOR.

▶ Command packet

1byte	1byte	1byte	1byte	1byte	1byte
Header	Data1	Data2	Data3	Data4	Checksum

- Header = 0xFF(Packet start)

- Data1 =

7 (=0b111)			ID					
7	6	5	4	3	2	1	0	

 bit number

※ ID : 0~30

- Data2 = 0x10

- Data3 = arbitrary

- Data4 = arbitrary

- Checksum = (Data1 XOR Data2 XOR Data3 XOR Data4) AND 0x7F

▶ Response packet

1 byte	1 byte
Threshold of Over-current	Threshold of Over-current

2.4. Position Control Function

When a user send his or her desired absolute position in the range of 0 to 254, the shaft of AI MOTOR is moved to the desired position. The position control function is executed by the 'Position Send Command'. Here, notice that the absolute position depends on the resolution.

Low Resolution Mode

Position control range is 0 to 332 degrees. Unit angle is about 1.307 degrees.

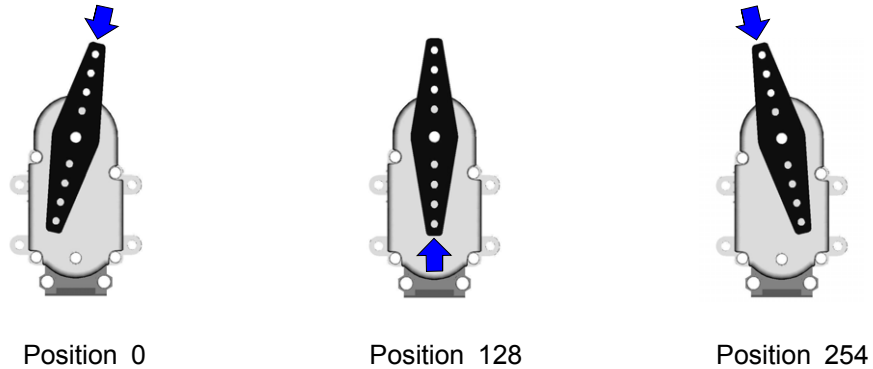

Figure 12. Position in Low Resolution Mode

※ Note : When Joint 1 or 2 or 10 be combined, it can be move in 66 ~ 207.
When Joint 6 was combined, it can be move in 43 ~ 186 or 86 ~ 229.

High Resolution Mode

Position control range is 0 to 166 degrees. Unit angle is about 0.654 degree.

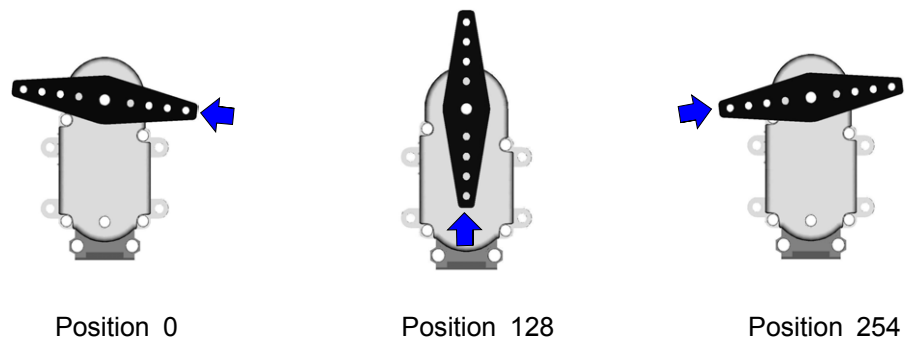

Figure 13. Position in High Resolution Mode

3. Appendix

3.1. RS-232 board

RS-232 board adjusts a signal level when connecting AI MOTOR to PC or another controller. Figure 14 illustrates connecting AI MOTOR to PC by using RS-232 board.

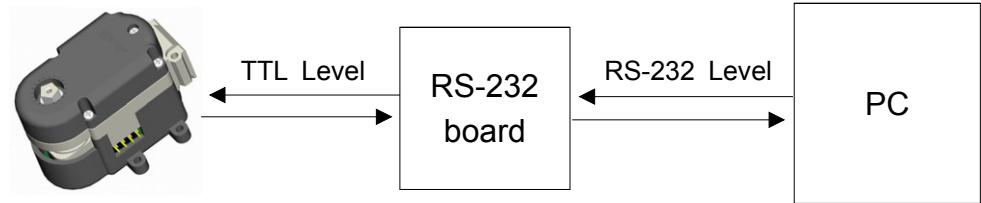

Figure 14. Function of RS-232 board

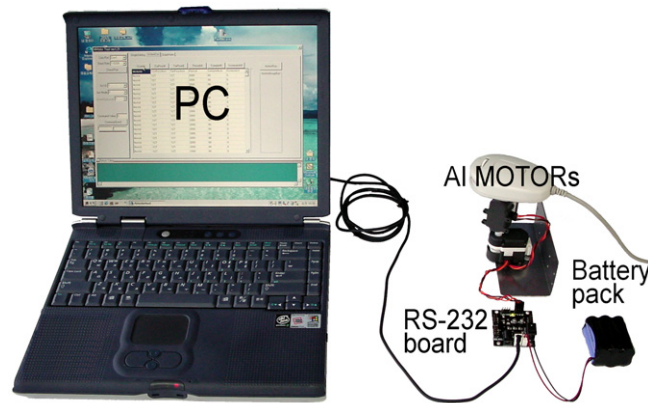

Figure 15. Connection of AI MOTORs to a PC

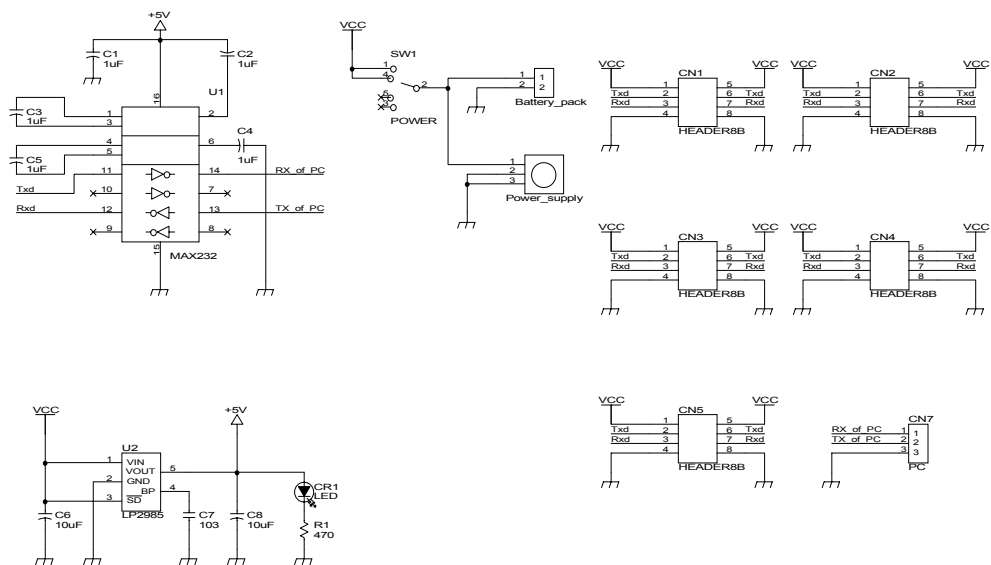

Figure 16. Schematic of RS-232 board

3.2. Application examples of AI MOTOR

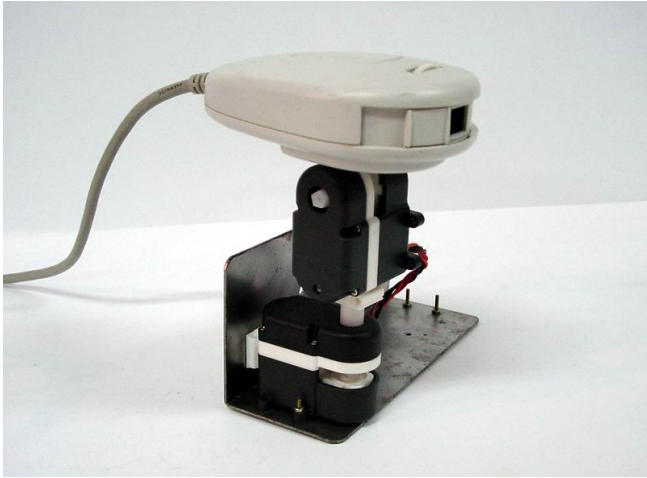

Figure 17. A pan-tilt structure using 2 AI-motors

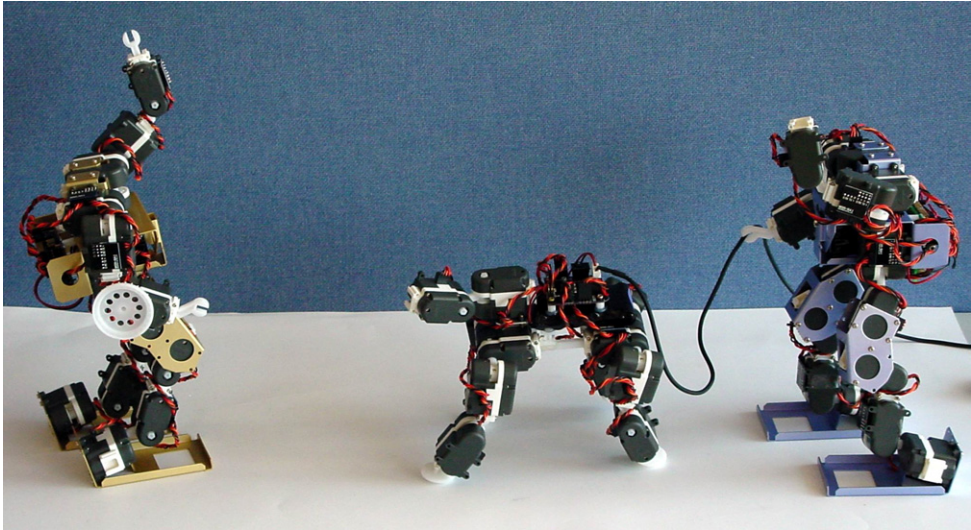

Figure 18. Humanoid robots and a Doggy robot