

Smart actuator module for legged robots

AI MOTOR-1001 MANUAL

Ver 1.02



Thank you for your purchasing our product. This manual shows how to use AI MOTOR-1001 neatly. Before using your AI MOTOR-1001, please read this manual carefully.



MEGAROBOTICS LTD.
www.megarobotics.com

CONTENTS

1. Introduction	
1.1. Summary	3
1.2. Package contents	3
1.3. Names of parts	4
1.4. Functions	5
1.5. Features and specifications	6
2. Detailed Description and Usage	
2.1. Hardware interface	8
2.2. Mechanical interface	12
2.3. Software interface	14
2.4. Position control function	23
3. Appendix	
3.1. RS-232 board	24
3.2. Examples of baud-rate for MCUs	25
3.3. Application examples of AI MOTOR	28
3.4. Example of program(1)	29
3.5. Example of program(2)	35

1. INTRODUCTION

1.1. Summary

AI MOTOR-1001 is a actuator module for legged robots that can assemble and control various types of robots. Motors are essential for all the moving devices. However, it is not available for general people since special devices and a lot of money are required in control, electronic circuit, and connection and combination of parts. AI MOTOR-1001 integrates motors, members and control circuits in one module so as to easily connect them to one another. Accordingly, if you use the product, you can design joints of a moving device simply and it is easy to expand the device additionally and to cope with troubles of the device. It is possible to connect motors to each other serially so as to simplify wiring. Control commands can be delivered once through a widely used RS-232 serial communication. Operation of motors can be monitored since AI MOTOR-1001 has a function of outputting the amount of the current flowing in the motor and position of the motor.

The operation modes are 360 degrees rotation mode, 0 to 332 degrees range position control mode, act down mode in which position change of the shaft of the motor can be monitored using external force by making torque of the shaft of the motor be zero, power down mode in which power consumption is minimized, synchronous position control mode.

The internal parameters of the motor can be changed by a program through serial communication. The changeable parameters are ID of the motor, baud-rate of the serial communication, position control resolution, position control gain, threshold of over-current, upper bound, lower bound. AI MOTOR-1001 internally confirms external power and controls internal control gain automatically so that constant control response is ensured though input voltage varies. It protects the motor against being damaged by cut off the motor current automatically when the current flowing in the motor is too much, where the threshold of over-current can be changed.

11 types of connecting parts are provided so as to assemble parts in various directions when connecting motors to each other. And also, since there are two shafts of the motor, it is very convenient to connect joints.

1.2. Package Contents

- ① AI MOTOR
- ② Cable 100mm
Cable 150mm
- ③ Joint parts (11 pieces)
- ④ Bolt M1.7 × 8 mm
Bolts M2.0 × 12 mm (2 pieces)
Bolts M2.0 × 16 mm (2 pieces)
Nuts M2.0 (4 pieces)



Figure 1. Package contents

1.3. Names of Parts

Disassembled view of body

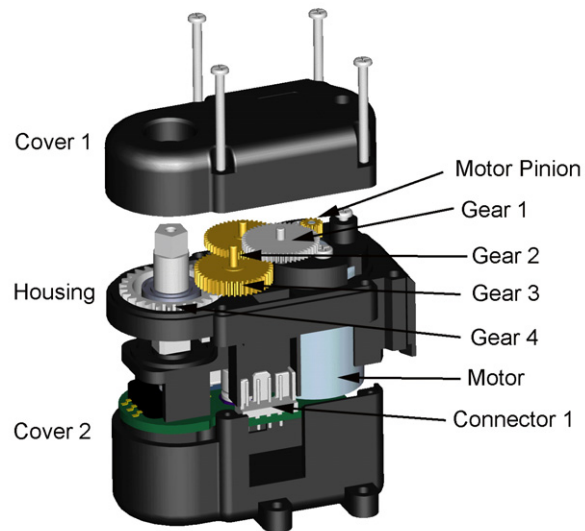

Figure 2. Disassembled view of body

Joint parts

Table 1. Usage of Joints

Usage	Joint part number
Shaft ↔ Body connection	1, 3, 6
Shaft ↔ Shaft connection	2, 10
Body ↔ Body connection	4, 8
Miscellaneous connection	5, 7, 9, 11

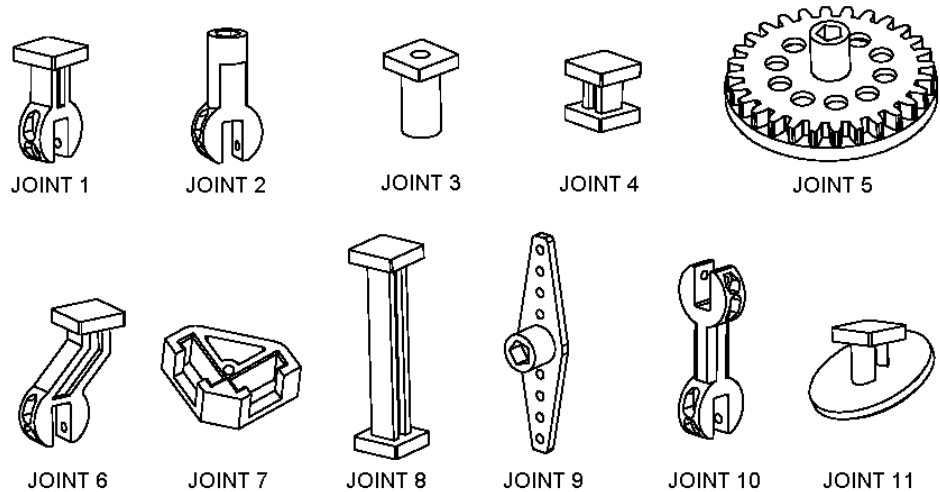

Figure 3. 11 types of Joints

Cable

Cable to connect motors to each other or connect a motor to a control board. Length are 10 cm, 15 cm respectively.



Figure 4. Cable

1.4. Functions

Position control function

Low resolution mode (0 to 332 degrees), High resolution mode (0 to 166 degrees)

Sensor function

Feedback of Current (8 bit) and Position (8 bit)

Speed control function

Position send mode 5 steps, 360 degrees rotation mode 16 steps

Resolution adjustment function (2 steps)

Low resolution 1.3 degrees, High resolution 0.65 degree

360 degrees rotation function (wheel operation mode)

Synchronous position control function

Position control of AI MOTORS start at the same time

Bound setting function

Position range of the shaft

Reverse voltage protection

0 to -28 V

Over-current protection

Settable range 400 to 1000 mA

Parameter setting function

ID, Baud-rate, resolution, threshold of over-current, P-gain, D-gain

Voltage sensing function

Internal control gain is set automatically depending on Input voltage (DC 5 to 10 V)

Mechanical direct connection between modules

Various connections are possible using 2 output shafts, body joint part and 11 types of joint parts.

Electrical direct connection between modules

Electrical direct connection are possible using two connector terminals and a connector cable.

Control signal I/O by communication

A full-duplex UART is built-in. The motors are controlled in RS-232 serial communication. 31 motors can be connected and controlled in one channel

1.5. Features and specifications

Advantages

- High performance to price
- Excellent assembly between motors
- Good gear endurance
- Various operation modes supplied
- Test tool program supplied
- Various application program supplied

Size

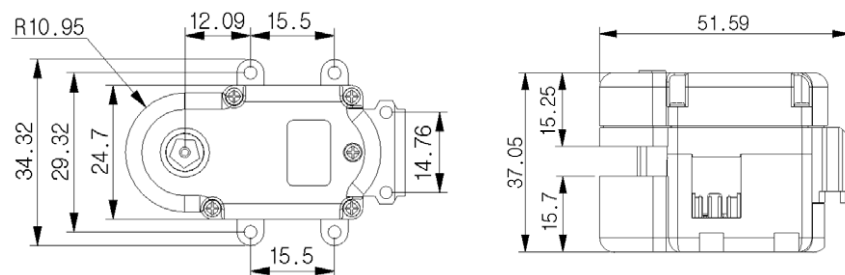

Figure 5. Size of Body

unit : mm

Specifications

Table 2. Specifications of AI MOTOR-1001

Communication	Standards		RS-232 asynchronous serial communication (TTL level)
	Capability of Connection		Maximum 31 per one communication channel
Parameter Range	ID		0 to 30
	Baud-rate		2400 to 460800 bps
	Resolution		Low Resolution (1.3 degrees) or High Resolution (0.65 degree)
	P-Gain		Recommended 1 to 50
	D-Gain		Recommended 0 to 100
	Threshold of Over-current		Approximate 400 mA to 1000 mA
	Lower bound, Upper bound		$0 \leq \text{Lower bound} < \text{Upper bound} \leq 254$
Operation	Maximum Torque		Approximate 10 Kg·cm (at +9.5 V)
	Maximum Speed		Approximate 60 rpm (at +9.5 V)
	Minimum Angle		Low resolution mode : $333.3/255 \approx 1.307$ degree High resolution mode : $166.65/255 \approx 0.654$ degree
Operation Mode	Position Send Mode	Speed Mode 0 (Fastest)	The present current and position are informed of and it moves to a specific position
		Speed Mode 1	
		Speed Mode 2	
		Speed Mode 3	
		Speed Mode 4 (Slowest)	
	Position Read Mode	The present current and position are informed of.	
Act Down Mode (Position Sensor Mode)	The present current and position are informed of, torque of the motor is removed, and the motor is moved by the external force.		
Power Down Mode	Power down state is maintained without torque of the motor until another command is received.		
360 degrees Rotation Mode	16 steps speed control(0: stop, 1: min, 15: max)		
Synchronous Position Control Mode	Position control of AI MOTORS start at the same time		
System Protection	Limitation of Over-current		Approximate 400 to 1000 mA (settable by user)
	Inverse Voltage Protection		0 to -28 V
Electrical	Motor	Types	DC precious metal brush motor
		Maximum Current	650 mA at DC 5V, 1000 mA at DC 10 V
	Control Circuit	Input Voltage Level	High(2.57 to 5.2V), Low(-0.5 to 0.94V)
		Output Voltage Level	High(3.25 to 4.7V), Low(0 to 0.6V)
Current	11.7 mA in general mode, 11.6 mA in power down mode		
Mechanical	Connecting Parts		11 types (Plastic)
	Size(Max.)		51.6 × 34.3 × 37.1 mm
	Weight		46 g
	Mutual Connecting Points		3 places
	Gear Ratio		1 : 241
	Gear Material		Metal, Plastic
	Bearing		Metal

Block diagram

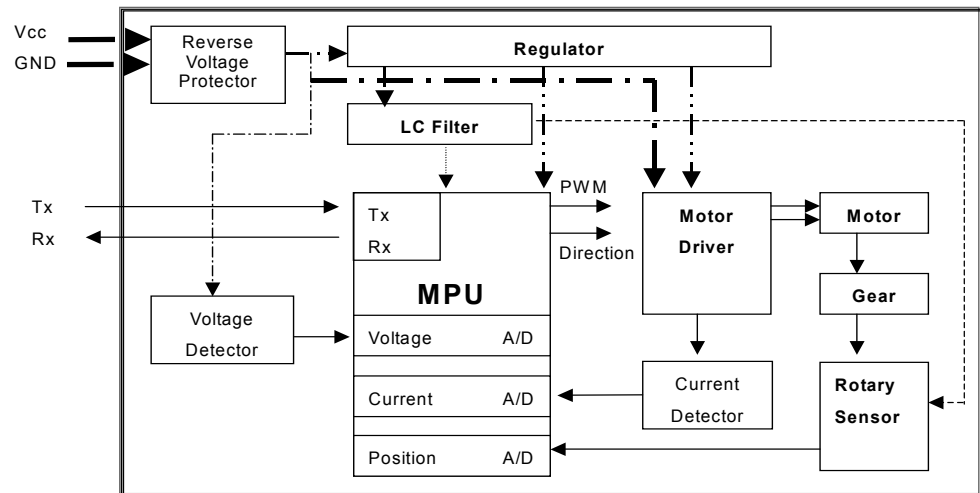

Figure 6. Block diagram of AI MOTOR-1001

2. Detailed Description and Usage

2.1. Hardware interface

Power supply and signal line used in a connector that is hardware interface of AI MOTOR will be described from now on.

Connector

AI MOTOR body has two connectors. Two connectors are connected to each other in parallel internally. You can use AI MOTOR if you connect any one of the two connectors. The other connector is used to connect another module in serial.

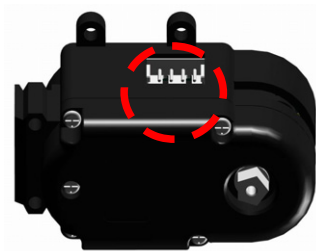

Connector 1



Connector 2

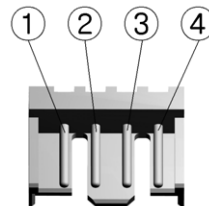

1: Ground, 2: RXD of AI MOTOR, 3: TXD of AI MOTOR, 4: Vcc

Figure 7. Connector

Electrical characteristics

Table 3. Maximum Operating Conditions

Symbol	Parameter	Min.	Max.	Unit
V _{CC}	Supply Voltage	4.5	10.5	V
I _{CC}	Operation Current	11.6	1015	mA
V _{IL}	Input Low Voltage	-0.5	0.94	V
V _{IH}	Input High Voltage	2.57	5.2	V
V _{OL}	Output Low Voltage	0	0.6	V
V _{OH}	Output High Voltage	3.25	4.7	V
T _O	Operating Temperature	0	70	°C
T _S	Storage Temperature	-40	120	°C

Table 4. Recommended Operating Conditions

Symbol	Parameter	Min.	Max.	Unit
V _{CC}	Supply Voltage	5.5	9	V
I _{CC}	Operation Current	-	600	mA
V _{IL}	Input Low Voltage	-0.5	1.2	V
V _{IH}	Input High Voltage	3.29	5.2	V
V _{OL}	Output Low Voltage	0	0.6	V
V _{OH}	Output High Voltage	4.0	4.7	V
T _O	Operating Temperature	10	40	°C
T _S	Storage Temperature	-40	80	°C

Power On Reset

No commands are received for 65 ms after turned on. After that, operating in act down mode.



Figure 8. Sequence of Power On Reset

RS-232 signal timing

Control commands and data are transmitted and received in asynchronous RS-232 communication of TTL level. At over 115200 bps, it need delay time over 150 us within the stop bit of a byte and the start bit of the next byte. At under 57600 bps, it need no delay time.

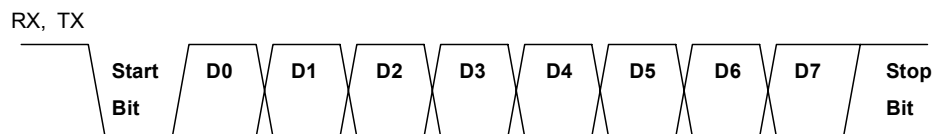

Figure 9. Signal Timing of RS-232 communication

RS-232 communication delay

Since AI MOTOR-1001 receives commands in RS-232 communication, all the motors do not receive commands at the same time in the case that a few modules are connected and the motors are controlled. Although communication delay is usually negligible, consider communication delay time shown in the following table and use AI MOTOR-1001.

Table 5. Delay Time of Communication

Baud-rate [bps]	1 byte transmission time [ms]	1 command (4 bytes) transmission time [ms]	1 command delay angle [Deg.] at 30 rpm
2400	4.167	16.667	3
4800	2.083	8.333	1.5
9600	1.042	4.167	0.75
19200	0.521	2.083	0.375
38400	0.260	1.042	0.1875
57600	0.174	0.694	0.0125
115200	0.087	0.347	0.0625
153600	0.065	0.260	0.046875
230400	0.043	0.174	0.03125
460800	0.022	0.087	0.015625

Response time

Table 7. shows the elapsed time after sending of command packet until receiving the response packet at various baud-rate.

Table 7. Response time(max.)

[unit : uS]

baudrate command	2400 bps	4800 bps	9600 bps	19200 bps	38400 bps	57600 bps	115200 bps
Position Send	25329	13159	7083	4045	2517	1354	1180
Position Read	25329	13159	7083	4045	2517	1354	1180
Act Down	25329	13159	7083	4045	2517	1354	1180
Power Down	25329	13159	7083	4045	2517	1354	1180
360 degrees Rotation	25329	13159	7083	4045	2517	1354	1180
Gain Read	33662	17326	9166	5086	3038	1701	1354
Resolution Read	33662	17326	9166	5086	3038	1701	1354
Overcurrent threshold read	33662	17326	9166	5086	3038	1701	1354
Bound Read	33662	17326	9166	5086	3038	1701	1354
Baudrate Set	153453	136144	127950	124877	122829	121492	121145
Gain Set	153453	136144	127950	124877	122829	121492	121145
ID Set	153453	136144	127950	124877	122829	121492	121145
Resolution Set	153453	136144	127950	124877	122829	121492	121145
Overcurrent threshold set	153453	136144	127950	124877	122829	121492	121145
Bound Set	153453	136144	127950	124877	122829	121492	121145

Position control response

Since control gain is set automatically owing to automatic voltage sensing function, it does not over-shoot though input voltage is raised up.

※ Conditions of Experiment

- Initial position : 15
- Target position : 165
- Load : 0
- Measuring time : 2 seconds
- Number of samples : 80

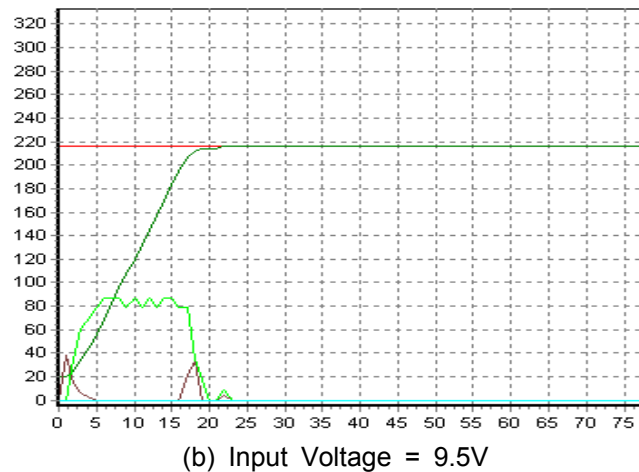
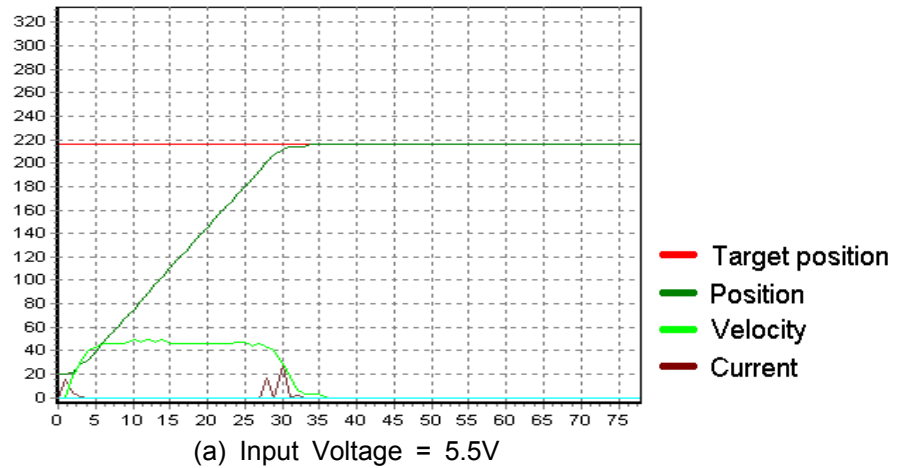



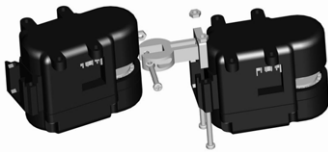

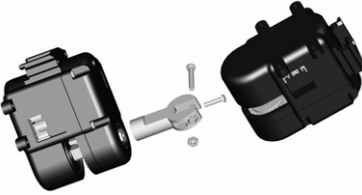









Figure 10. Response of Position Send Command















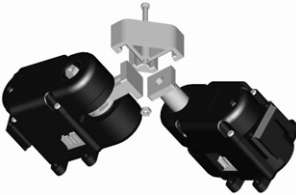
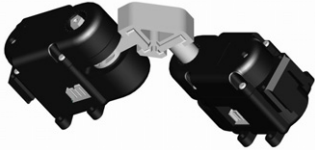

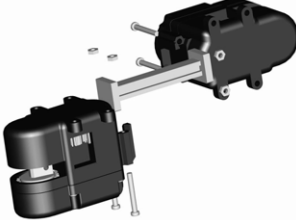
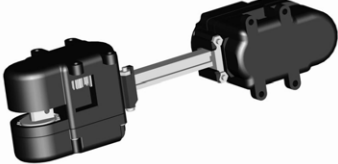
2.2. Mechanical interface

The usage of a body joint part, an output shaft and a joint part which are mechanical parts of AI MOTOR will be taught.

Types and examples of joint parts

Table 6. Usage of Joints

Joint parts	Assembly forms	Assembled appearances
 <p>JOINT 1</p>		
 <p>JOINT 2</p>		
 <p>JOINT 3</p>		
 <p>JOINT 4</p>		
 <p>JOINT 5</p>		

Joint parts	Assembly forms	Assembled appearances
 <p data-bbox="544 423 654 454">JOINT 6</p>		
 <p data-bbox="544 714 652 745">JOINT 7</p>		
 <p data-bbox="544 1057 654 1088">JOINT 8</p>		
 <p data-bbox="544 1290 652 1321">JOINT 9</p>		
 <p data-bbox="536 1639 660 1671">JOINT 10</p>		
 <p data-bbox="536 1904 657 1935">JOINT 11</p>		

2.3. Software interface

Communication protocol that is software interface of AI MOTOR will be described.

2.3.1. Communication flow

All the communication commands flow as illustrated in the following figure. When a controller sends a command packet to AI MOTOR, AI MOTOR returns a response packet to the controller.

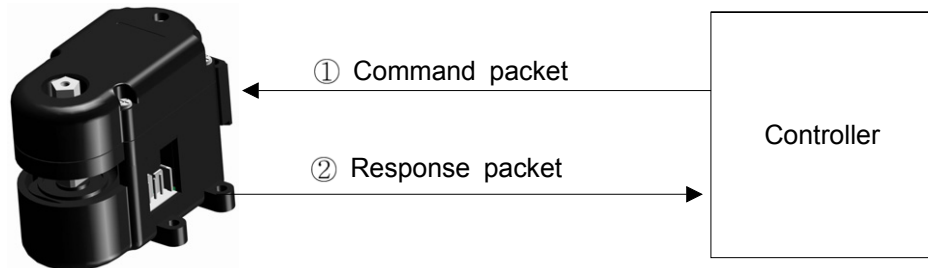

Figure 11. Flow of Communication

2.3.2. Command Packet

There are two kinds of command packets, that is, an operation command packet and a setting command packet (6 bytes).

2.3.2.1. Operation Command Packet

Position Send Command

Command to return to the other controller the present current of AI MOTOR and the present position of output shaft, and move to a desired location. The speed can be controlled in 5 levels.

► Command Packet

1byte	1byte	1byte	1byte
Header	Data1	Data2	Checksum

- Header = 0xFF(Packet start)

- Data1 =

Speed			ID				
7	6	5	4	3	2	1	0

} bit number

※ Speed : 0(fastest)~4(slowest)

ID : 0~30

- Data2 = 0~254(Target position)

- Checksum = (Data1 XOR Data2) AND 0x7F

► Response Packet

1 byte	1 byte
Current	Position

- Current = approximate 18.4 mA per 1

- Position = 0~255

Position Read Command

Command to return the present current of AI MOTOR and the present position of output shaft

► Command Packet

1byte	1byte	1byte	1byte
Header	Data1	Data2	Checksum

- Header = 0xFF(Packet start)

- Data1 =

5 (=0b101)					ID			
7	6	5	4	3	2	1	0	

 bit number
 ※ ID : 0~30

- Data2 = arbitrary

- Checksum = (Data1 XOR Data2) AND 0x7F

► Response Packet

1 byte	1 byte
Current	Position

- Current = approximate 18.4 mA per 1

- Position = 0~255

Act Down Command

Command to send the present position of output shaft and remove torque of the motor to move due to external force.

► Command Packet

1byte	1byte	1byte	1byte
Header	Data1	Data2	Checksum

- Header = 0xFF(Packet start)

- Data1 =

6 (=0b110)						ID	
7	6	5	4	3	2	1	0

 bit number
 ※ ID : 0~30

- Data2 =

1 (=0b0001)				Arbitrary			
7	6	5	4	3	2	1	0

 bit number

- Checksum = (Data1 XOR Data2) AND 0x7F

► Response Packet

1 byte	1 byte
Data2	Position

- Position = 0~255

Power Down Command

All the connected AI MOTORS are powered down. If a communication command is received, AI MOTORS are awakened.

Command to send the present position of output shaft and remove torque of the motor to move due to external force.

▶ Command Packet

1byte	1byte	1byte	1byte
Header	Data1	Data2	Checksum

- Header = 0xFF(Packet start)

- Data1 =

6 (=0b110)			31 (=0b11111)				
7	6	5	4	3	2	1	0

 bit number

- Data2 =

2 (=0b0010)				Arbitrary			
7	6	5	4	3	2	1	0

 bit number

- Checksum = (Data1 XOR Data2) AND 0x7F

▶ Response Packet

1 byte	1 byte
ID	Position

360 degrees Rotation Command

Command to rotate the shaft of AI MOTOR by 360 degrees. Its speed can be controlled in 16 levels.

▶ Command Packet

1byte	1byte	1byte	1byte
Header	Data1	Data2	Checksum

- Header = 0xFF(Packet start)

- Data1 =

6 (=0b110)			ID				
7	6	5	4	3	2	1	0

 bit number

※ ID : 0~30

- Data2 =

Direction				Speed			
7	6	5	4	3	2	1	0

 bit number

※ Direction : 3(CCW), 4(CW)

Speed : 0(stop), 1(min)~15(max)

- Checksum = (Data1 XOR Data2) AND 0x7F

▶ Response Packet

1 byte	1 byte
Rotations	Position

- Rotations = 0~255(rotations after power-on, ⊕ : CCW, ⊖ : CW)

- Position = 0~255

Synchronous Position Send Command

Command to control several AI MOTORS at the same time. The speed can be controlled in 5 levels.

► Command Packet

1byte	1byte	1byte	1byte	...	1byte	1byte
Header	Data1	Last ID+1	Pos[0]	...	Pos[Last ID]	Checksum

- Header = 0xFF(Packet start)

Speed	31 (=0b11111)							
7	6	5	4	3	2	1	0	bit number

※ Speed : 0(fastest)~4(slowest)

- Last ID = 0~30(ID of the last AI MOTOR)

- Pos[0] = 0~254(Target position of the ID 0)

⋮

- Pos[Last ID]= 0~254(Target position of the Last ID)

- Checksum = (Pos[0] XOR Pos[1] ⋯ XOR Pos[Last ID]) AND 0x7F

► Response Packet

- none

2.3.2.2. Setting command packet (6 bytes)

Baud-rate Set Command

Command to set the Baud-rate of AI MOTOR. Supplied Baud-rate is 2400, 4800, 9600, 19200, 38400, 57600, 115200, 230400, 307200 and 460800 bps.

► Command packet

1byte	1byte	1byte	1byte	1byte	1byte
Header	Data1	Data2	Data3	Data4	Checksum

- Header = 0xFF(Packet start)

7 (=0b111)	ID							
7	6	5	4	3	2	1	0	bit number

※ ID : 0~30

- Data2 = 0x08

- Data3 = 0(460800bps), 1(230400bps), 2(153600bps),
3(115200bps), 7(57600bps), 11(38400bps), 23(19200bps),
47(9600bps), 95(4800bps), 191(2400bps)

- Data4 = Data3

- Checksum = (Data1 XOR Data2 XOR Data3 XOR Data4) AND 0x7F

► Response packet

1 byte	1 byte
New Baud-rate	New Baud-rate

- New Baud-rate = 0~191

Control Gain Set Command

Command to set the control gains of AI MOTOR. The settable control gains are proportional gain and differentiating gain.

▶ Command packet

1byte	1byte	1byte	1byte	1byte	1byte
Header	Data1	Data2	Data3	Data4	Checksum

- Header = 0xFF(Packet start)

- Data1 =

7 (=0b111)	ID						
7	6	5	4	3	2	1	0

 bit number

※ ID : 0~30

- Data2 = 0x09

- Data3 = recommended 1~50(New P-gain)

- Data4 = recommended 0~100(New D-gain)

- Checksum = (Data1 XOR Data2 XOR Data3 XOR Data4) AND 0x7F

▶ Response packet

1 byte	1 byte
New P-gain	New D-gain

- New P-gain = 1~50

- New D-gain = 0~100

ID Set Command

Command to set the ID of AI MOTOR.

▶ Command packet

1byte	1byte	1byte	1byte	1byte	1byte
Header	Data1	Data2	Data3	Data4	Checksum

- Header = 0xFF(Packet start)

- Data1 =

7 (=0b111)	ID						
7	6	5	4	3	2	1	0

 bit number

※ ID : 0~30

- Data2 = 0x0A

- Data3 = 0~30(New ID)

- Data4 = Data3

- Checksum = (Data1 XOR Data2 XOR Data3 XOR Data4) AND 0x7F

▶ Response packet

1 byte	1 byte
New ID	New ID

- New ID = 0~30

Control Gain Read Command

Command to read the control gain of AI MOTOR.

▶ Command packet

1byte	1byte	1byte	1byte	1byte	1byte
Header	Data1	Data2	Data3	Data4	Checksum

- Header = 0xFF(Packet start)

- Data1 =

7 (=0b111)			ID				
7	6	5	4	3	2	1	0

 bit number

※ ID : 0~30

- Data2 = 0x0C

- Data3 = arbitrary

- Data4 = arbitrary

- Checksum = (Data1 XOR Data2 XOR Data3 XOR Data4) AND 0x7F

▶ Response packet

1 byte	1 byte
P-gain	D-gain

- P-gain = 1~50

- D-gain = 1~100

Resolution Set Command

Command to set the resolution of AI MOTOR.

▶ Command packet

1byte	1byte	1byte	1byte	1byte	1byte
Header	Data1	Data2	Data3	Data4	Checksum

- Header = 0xFF(Packet start)

- Data1 =

7 (=0b111)			ID				
7	6	5	4	3	2	1	0

 bit number

※ ID : 0~30

- Data2 = 0x0D

- Data3 = 0(Low resolution), 1(High resolution)

- Data4 = Data3

- Checksum = (Data1 XOR Data2 XOR Data3 XOR Data4) AND 0x7F

▶ Response packet

1 byte	1 byte
New Resolution	New Resolution

- New Resolution = 0(Low resolution), 1(High resolution)

Resolution Read Command

Command to read the resolution of AI MOTOR.

► Command packet

1byte	1byte	1byte	1byte	1byte	1byte
Header	Data1	Data2	Data3	Data4	Checksum

- Header = 0xFF(Packet start)

- Data1 =

7 (=0b111)			ID				
7	6	5	4	3	2	1	0

 bit number

※ ID : 0~30

- Data2 = 0x0E

- Data3 = arbitrary

- Data4 = arbitrary

- Checksum = (Data1 XOR Data2 XOR Data3 XOR Data4) AND 0x7F

► Response packet

1 byte	1 byte
Resolution	Resolution

- Resolution = 0(Low resolution), 1(High resolution)

Threshold of Over-Current Set Command

Command to set the threshold of over-current of AI MOTOR.

※ Note : If over-current occurred, it would be act-down mode.

► Command packet

1byte	1byte	1byte	1byte	1byte	1byte
Header	Data1	Data2	Data3	Data4	Checksum

- Header = 0xFF(Packet start)

- Data1 =

7 (=0b111)			ID				
7	6	5	4	3	2	1	0

 bit number

※ ID : 0~30

- Data2 = 0x0F

- Data3 = 22~54 (=Coefficient × threshold of over-current in mA)
ex) 22 ≙ 0.054468085 × 403.9 mA

- Data4 = Data3

- Checksum = (Data1 XOR Data2 XOR Data3 XOR Data4) AND 0x7F

► Response packet

1 byte	1 byte
New Threshold of Over-current	New Threshold of Over-current

- New Threshold of Over-current

= 22~54 (=Coefficient × threshold of over-current in mA)

Threshold of Over-Current Read Command

Command to read the threshold of over-current of AI MOTOR.

► Command packet

1byte	1byte	1byte	1byte	1byte	1byte
Header	Data1	Data2	Data3	Data4	Checksum

- Header = 0xFF(Packet start)

- Data1 =

7 (=0b111)			ID					
7	6	5	4	3	2	1	0	

 bit number

※ ID : 0~30

- Data2 = 0x10

- Data3 = arbitrary

- Data4 = arbitrary

- Checksum = (Data1 XOR Data2 XOR Data3 XOR Data4) AND 0x7F

► Response packet

1 byte	1 byte
Threshold of Over-current	Threshold of Over-current

Bound Set Command

Command to set the upper bound and the lower bound of the position range

► Command packet

1byte	1byte	1byte	1byte	1byte	1byte
Header	Data1	Data2	Data3	Data4	Checksum

- Header = 0xFF(Packet start)

- Data1 =

7 (=0b111)			ID					
7	6	5	4	3	2	1	0	

 bit number

※ ID : 0~30

- Data2 = 0x11

- Data3 = 0~254(Minimum position)

- Data4 = 0~254(Maximum position)

- Checksum = (Data1 XOR Data2 XOR Data3 XOR Data4) AND 0x7F

► Response packet

1 byte	1 byte
New lower bound	New upper bound

Bound Read Command

Command to read the upper bound and the lower bound of the position range

► Command packet

1byte	1byte	1byte	1byte	1byte	1byte
Header	Data1	Data2	Data3	Data4	Checksum

- Header = 0xFF(Packet start)

- Data1 =

7 (=0b111)	ID						
7	6	5	4	3	2	1	0

 bit number

※ ID : 0~30

- Data2 = 0x12

- Data3 = arbitrary

- Data4 = arbitrary

- Checksum = (Data1 XOR Data2 XOR Data3 XOR Data4) AND 0x7F

► Response packet

1 byte	1 byte
Lower bound	Upper bound

2.4. Position Control Function

When a user send his or her desired absolute position in the range of 0 to 254, the shaft of AI MOTOR is moved to the desired position. The position control function is executed by the 'Position Send Command'. Here, notice that the absolute position depends on the resolution.

Low Resolution Mode

Position control range is 0 to 332 degrees. Unit angle is about 1.307 degrees.

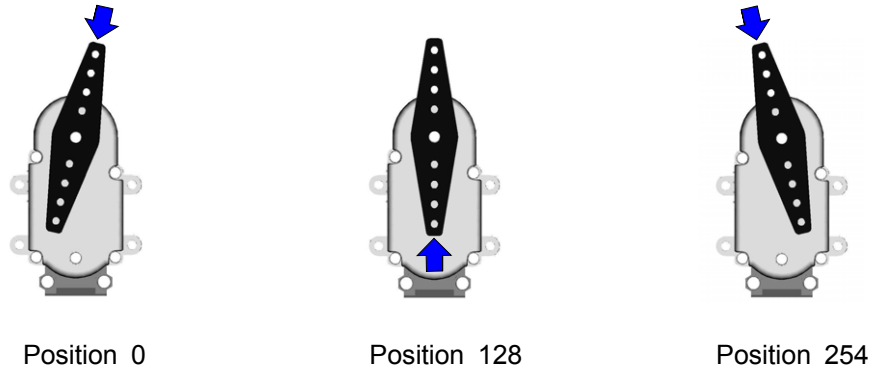

Figure 12. Position in Low Resolution Mode

※ Note : When Joint 1 or 2 or 10 be combined, it can be move in 66 ~ 207.
When Joint 6 was combined, it can be move in 43 ~ 186 or 86 ~ 229.

High Resolution Mode

Position control range is 0 to 166 degrees. Unit angle is about 0.654 degree.

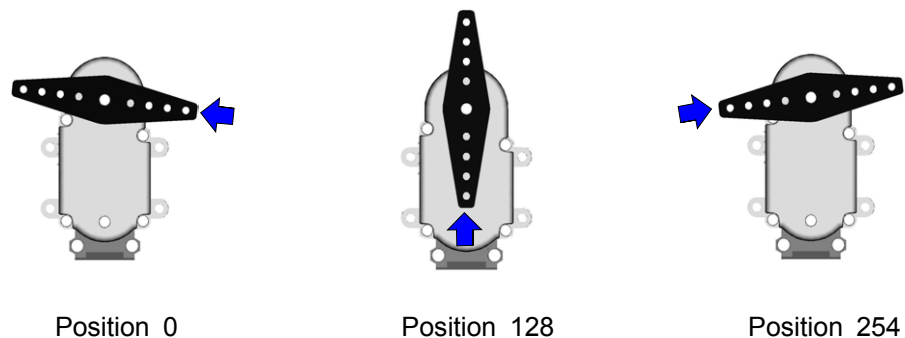

Figure 13. Position in High Resolution Mode

3. Appendix

3.1. RS-232 board

RS-232 board adjusts a signal level when connecting AI MOTOR to PC or another controller. Figure 14 illustrates connecting AI MOTOR to PC by using RS-232 board.

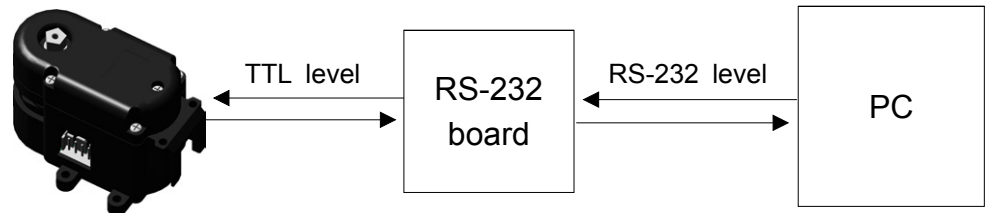

Figure 14. Function of RS-232 board

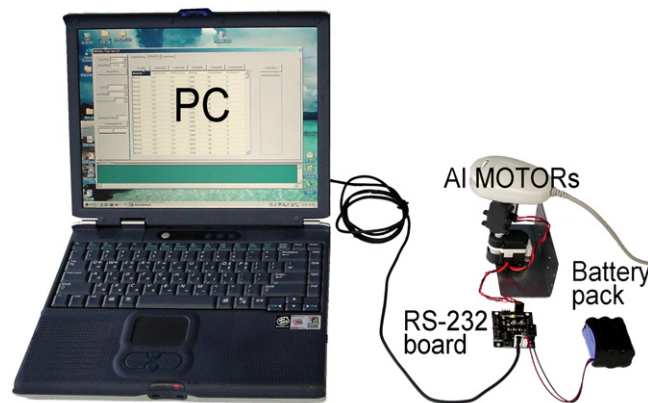

Figure 15. Connection of AI MOTORS to a PC

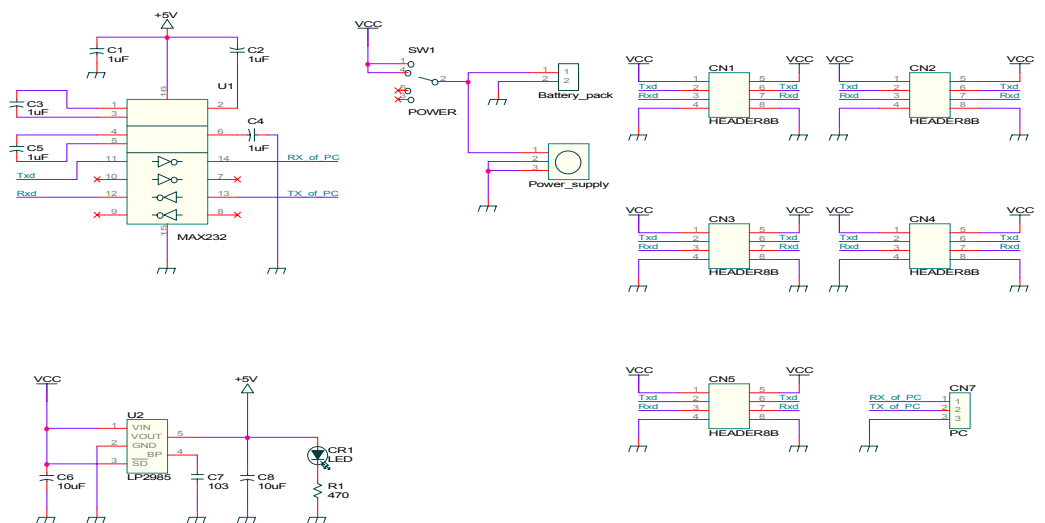

Figure 16. Schematic of RS-232 board

3.2. Examples of baud-rate for MCUs

We recommend the following configuration that minimize communication error.

MCS51 Family(Timer1 use, Mode1)

Clock[Mhz]	SMOD	TH1	Baud-rate[bps]	Error[%]
7.3728	0	248	2400	0
7.3728	1	240	2400	0
7.3728	0	252	4800	0
7.3728	1	248	4800	0
7.3728	0	254	9600	0
7.3728	1	252	9600	0
7.3728	0	255	19200	0
7.3728	1	254	19200	0
7.3728	1	255	38400	0
11.0592	0	244	2400	0
11.0592	1	232	2400	0
11.0592	0	250	4800	0
11.0592	1	244	4800	0
11.0592	0	253	9600	0
11.0592	1	250	9600	0
11.0592	1	253	19200	0
11.0592	1	255	57600	0
14.7456	0	240	2400	0
14.7456	1	224	2400	0
14.7456	0	248	4800	0
14.7456	1	240	4800	0
14.7456	0	252	9600	0
14.7456	1	248	9600	0
14.7456	0	254	19200	0
14.7456	1	252	19200	0
14.7456	0	255	38400	0
14.7456	1	254	38400	0
22.1184	0	232	2400	0
22.1184	1	208	2400	0
22.1184	0	244	4800	0
22.1184	1	232	4800	0
22.1184	0	250	9600	0
22.1184	1	244	9600	0
22.1184	0	253	19200	0
22.1184	1	250	19200	0
22.1184	1	253	38400	0
22.1184	0	255	57600	0
22.1184	1	254	57600	0
22.1184	1	255	115200	0

80c196Kx(Mode1)

Clock[Mhz]	SP_BAUD	Baud-rate[bps]	Error[%]
7.3728	80BF	2400	0
7.3728	805F	4800	0
7.3728	802F	9600	0
7.3728	8017	19200	0
7.3728	800B	38400	0
7.3728	8007	57600	0
7.3728	8003	115200	0
11.0592	811F	2400	0
11.0592	808F	4800	0
11.0592	8047	9600	0
11.0592	8023	19200	0
11.0592	8011	38400	0
11.0592	800B	57600	0
11.0592	8005	115200	0
11.0592	8002	230400	0
14.7456	817F	2400	0
14.7456	80BF	4800	0
14.7456	805F	9600	0
14.7456	802F	19200	0
14.7456	8017	38400	0
14.7456	800F	57600	0
14.7456	8007	115200	0
14.7456	8003	230400	0

PIC Family

Clock[Mhz]	BRGH	SPBRG	Baud-rate[bps]	Error[%]
3.6864	0	23	2400	0
3.6864	0	11	4800	0
3.6864	0	5	9600	0
3.6864	0	2	19200	0
3.6864	0	0	57600	0
7.3728	0	47	2400	0
7.3728	0	23	4800	0
7.3728	0	11	9600	0
7.3728	0	5	19200	0
7.3728	0	2	38400	0
7.3728	0	1	57600	0
7.3728	0	0	115200	0
11.0592	0	71	2400	0
11.0592	0	35	4800	0
11.0592	0	17	9600	0
11.0592	0	8	19200	0
11.0592	0	2	57600	0
14.7456	0	95	2400	0
14.7456	0	47	4800	0
14.7456	0	11	19200	0
14.7456	0	5	38400	0
14.7456	0	3	57600	0
14.7456	0	1	115200	0
14.7456	0	0	230400	0

AVR Family

Clock[Mhz]	UBRRH	UBRRL	Baud-rate[bps]	Error[%]
7.3728	0	191	2400	0
7.3728	0	95	4800	0
7.3728	0	47	9600	0
7.3728	0	23	19200	0
7.3728	0	11	38400	0
7.3728	0	7	57600	0
7.3728	0	3	115200	0
7.3728	0	1	230400	0
7.3728	0	0	460800	0
14.7456	1	127	2400	0
14.7456	0	191	4800	0
14.7456	0	95	9600	0
14.7456	0	47	19200	0
14.7456	0	23	38400	0
14.7456	0	15	57600	0
14.7456	0	7	115200	0
14.7456	0	3	230400	0
14.7456	0	1	460800	0

3.2. Application examples of AI MOTOR

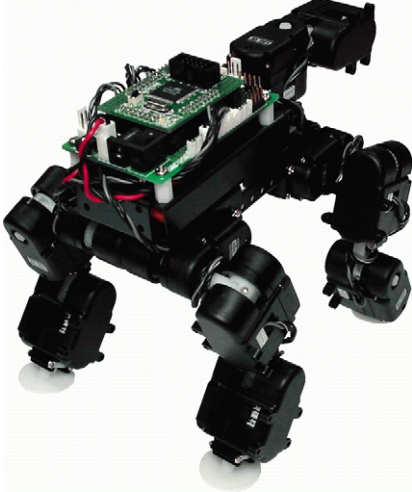

Figure 17. 4-legged robot



Figure 18. Humanoid robot



Figure 19. A Pan-tilt structure using 2 AI-motors

3.4. Example of program(1)

This is an example of program in pseudo C code. Because The function of serial communication depends on the CPU, you should modify the serial functions.

```
/*=====*/
/* AI MOTOR example code */
/* description : If you move the shaft, the shaft rotate the same direction */
/*              and stop. */
/* principal : Using position feed back function of AI MOTOR, the program */
/*              detect the variation of position and direction */
/*=====*/
#define HEADER      0xff
#define NULL        0
#define ROTATE_CCW  3
#define ROTATE_CW   4
#define TIME_OUT1   35 //Max.response time of operation command is about 35ms
#define TIME_OUT2   155 //Max.response time of setting command is about 155ms

/* Function prototype start -----*/
/*----- Serial communication functions (CPU dependent) -----*/
void SendByte(char data); // Send a byte to serial port
void GetByte(char timeout); // Receive a byte from serial port
/*----- AI-Motor functions -----*/
void SendOperCommand(char Data1, char Data2);
void SendSetCommand(char Data1, char Data2, char Data3, char Data4);
char PosSend(char ServoID, char SpeedLevel, char Position);
char PosRead(char ServoID);
char ActDown(char ServoID);
char PowerDown(void);
char Rotation360(char ServoID, char SpeedLevel, char RotationDir);
void SyncPosSend(char LastID, char SpeedLevel, char *TargetArray, char Index);
char BaudrateSet(char ServoID, char NewBaud);
char GainSet(char ServoID, char *NewPgain, char *NewDgain);
char IdSet(char ServoID, char NewId);
char GainRead(char ServoID, char *Pgain, char *Dgain);
char ResolSet(char ServoID, char NewResol);
char ResolRead(char ServoID);
char OverCTSet(char ServoID, char NewOverCT);
char OverCTRead(char ServoID);
char BoundSet(char ServoID, char *NewLBound, char *NewUBound);
char BoundRead(char ServoID, char *LBound, char *UBound);
/*----- Function prototype end */

void main(void)
{
    char i, old_position;

    Initialize(); // peripheral initialization

    id = 0;
    old_position = ActDown(id); // ID 0 position read firstly
    while(1) {
        now_position = ActDown(id); // get now position

        if(now_position<old_position) { // if the position decreased
            Rotation360(id, 10, ROTATE_CCW);
            delay_ms(1000);
            ActDown(id);
            delay_ms(1000);
        }
    }
}
```

}

```

        else if(now_position>old_position){// if the position increased
            Rotation360(id, 10, ROTATE_CW);
            delay_ms(1000);
            ActDown(id);
            delay_ms(1000);
        }
        old_position = ActDown(id); // memory position
        delay_ms(300);
    }
}

//////////////////////////////////// Function declaration start //////////////////////////////////////
/*****
/* Send an operation command(4byte) to AI-motor */
/* Input : Data1, Data2 */
/* Output : None */
*****/
void SendOperCommand(char Data1, char Data2)
{
    char CheckSum;
    CheckSum = (Data1^Data2)&0x7f;
    SendByte(HEADER);
    SendByte(Data1);
    SendByte(Data2);
    SendByte(CheckSum);
}

/*****
/* Send a setting command(6byte) to AI-motor */
/* Input : Data1, Data2, Data3, Data4 */
/* Output : None */
*****/
void SendSetCommand(char Data1, char Data2, char Data3, char Data4)
{
    char CheckSum;
    CheckSum = (Data1^Data2^Data3^Data4)&0x7f;
    SendByte(HEADER);
    SendByte(Data1);
    SendByte(Data2);
    SendByte(Data3);
    SendByte(Data4);
    SendByte(CheckSum);
}

/*****
/* Send a position send command to AI-motor */
/* Input : ServoID, SpeedLevel, Position */
/* Output : Current */
*****/
char PosSend(char ServoID, char SpeedLevel, char Position)
{
    char Current;
    SendOperCommand((SpeedLevel<<5)|ServoID, Position);
    GetByte(TIME_OUT1);
    Current = GetByte(TIME_OUT1);
    return Current;
}

```

```

/*****
/* Send a position read command to AI-motor */
/* Input : ServoID */
/* Output : Position */
/*****
char PosRead(char ServoID)
{
    char Position;
    SendOperCommand(0xa0|ServoID, NULL);
    GetByte(TIME_OUT1);
    Position = GetByte(TIME_OUT1);
    return Position;
}

/*****
/* Send an act down command to AI-motor */
/* Input : ServoID */
/* Output : Position */
/*****
char ActDown(char ServoID)
{
    char Position;
    SendOperCommand(0xc0|ServoID, 0x10);
    GetByte(TIME_OUT1);
    Position = GetByte(TIME_OUT1);
    return Position;
}

/*****
/* Send a power down command to AI-motor */
/* Input : None */
/* Output : ServoID(success), 0xff(fail) */
/*****
char PowerDown(void)
{
    char ServoID;
    SendOperCommand(0xdf, 0x20);
    ServoID = GetByte(TIME_OUT1);
    GetByte(TIME_OUT1);
    if(ServoID<31) return ServoID;
    return 0xff; //Receive error
}

/*****
/* Send a 360degrees rotation command to AI-motor */
/* Input : ServoID, SpeedLevel, RotationDir */
/* Return : Rotation Number */
/*****
char Rotation360(char ServoID, char SpeedLevel, char RotationDir)
{
    char ServoPos, RotNum;
    if(RotationDir==ROTATE_CCW) {
        SendOperCommand((6<<5)|ServoID, (ROTATE_CCW<<4)|SpeedLevel);
    }
    else if(RotationDir==ROTATE_CW) {
        SendOperCommand((6<<5)|ServoID, (ROTATE_CW<<4)|SpeedLevel);
    }
    RotNum = GetByte(TIME_OUT1);
    GetByte(TIME_OUT1);
    return RotNum;
}

```

```

/*****
/* Send a synchronous position send command to AI-motor */
/* Input : LastID, SpeedLevel, *TargetArray, Index */
/* Return : None */
/*****
void SyncPosSend(char LastID, char SpeedLevel, char *TargetArray, char Index)
{
    int i;
    char CheckSum;
    i = 0;
    CheckSum = 0;
    SendByte(HEADER);
    SendByte((SpeedLevel<<5)|0x1f);
    SendByte(LastID+1);
    while(1) {
        if(i>LastID) break;
        SendByte(TargetArray[Index*(LastID+1)+i]);
        CheckSum = CheckSum ^ TargetArray[Index*(LastID+1)+i];
        i++;
    }
    CheckSum = CheckSum & 0x7f;
    SendByte(CheckSum);
}

/*****
/* Send a baudrate set command to AI-motor */
/* Input : ServoID, NewBaud */
/* Return : New Baudrate(success), 0xff(fail) */
/*****
char BaudrateSet(char ServoID, char NewBaud)
{
    SendSetCommand((7<<5)|ServoID, 0x08, NewBaud, NewBaud);
    GetByte(TIME_OUT2);
    if(GetByte(TIME_OUT2)==NewBaud) return NewBaud;
    return 0xff;
}

/*****
/* Send a gain set command to AI-motor */
/* Input : ServoID, *NewPgain, *NewDgain */
/* Return : 1(success), 0(fail) */
/*****
char GainSet(char ServoID, char *NewPgain, char *NewDgain)
{
    char Data1,Data2;
    SendSetCommand((7<<5)|ServoID, 0x09, *NewPgain, *NewDgain);
    Data1 = GetByte(TIME_OUT2);
    Data2 = GetByte(TIME_OUT2);
    if((Data1==*NewPgain) && (Data2==*NewDgain)) return 1;
    return 0;
}

```

```

/*****
/* Send an ID set command to AI-motor */
/* Input : ServoID, NewId */
/* Return : New ID(success), 0xff(fail) */
/*****
char IdSet(char ServoID, char NewId)
{
    SendSetCommand((7<<5)|ServoID, 0x0a, NewId, NewId);
    GetByte(TIME_OUT2);
    if(GetByte(TIME_OUT2)==NewId) return NewId;
    return 0xff;
}

/*****
/* Send a gain read command to AI-motor */
/* Input : ServoID, *NewPgain, *NewDgain */
/* Return : 1(success), 0(fail) */
/*****
char GainRead(char ServoID, char *Pgain, char *Dgain)
{
    SendSetCommand((7<<5)|ServoID, 0x0c, 0, 0);
    *Pgain = GetByte(TIME_OUT1);
    *Dgain = GetByte(TIME_OUT1);
    if((*Pgain>0) && (*Pgain<51) && (*Dgain<101)) return 1;
    return 0;
}

/*****
/* Send a resolution set command to AI-motor */
/* Input : ServoID, NewResol */
/* Return : New Resolution(success), 0xff(fail) */
/*****
char ResolSet(char ServoID, char NewResol)
{
    SendSetCommand((7<<5)|ServoID, 0x0d, NewResol, NewResol);
    GetByte(TIME_OUT2);
    if(GetByte(TIME_OUT2)==NewResol) return NewResol;
    return 0xff;
}

/*****
/* Send a resolution read command to AI-motor */
/* Input : ServoID */
/* Return : Resolution(success), 0xff(fail) */
/*****
char ResolRead(char ServoID)
{
    char Data1;
    SendSetCommand((7<<5)|ServoID, 0x0e, 0, 0);
    sciRxReady(TIME_OUT1);
    Data1=sciRxReady(TIME_OUT1);
    if(Data1<2) return Data1;
    return 0xff;
}

```

```

/*****
/* Send an overcurrent threshold set command to AI-motor */
/* Input : ServoID, NewOverCT */
/* Return : New Overcurrent Threshold(success), 0xff(fail) */
/*****
char OverCTSet(char ServoID, char NewOverCT)
{
    char Data1;
    SendSetCommand((7<<5)|ServoID, 0x0f, NewOverCT, NewOverCT);
    sciRxReady(TIME_OUT2);
    Data1=sciRxReady(TIME_OUT2);
    if(Data1!=0xff) return Data1;
    return 0xff;
}

/*****
/* Send an overcurrent threshold read command to AI-motor */
/* Input : ServoID */
/* Return : Overcurrent Threshold(success), 0xff(fail) */
/*****
char OverCTRead(char ServoID)
{
    char Data1;
    SendSetCommand((7<<5)|ServoID, 0x10, 0, 0);
    sciRxReady(TIME_OUT1);
    Data1=sciRxReady(TIME_OUT1);
    if(Data1!=0xff) return Data1;
    return 0xff;
}

/*****
/* Send a bound set command to AI-motor */
/* Input : ServoID, *NewLBound, *NewUBound */
/* Return : 1(success), 0(fail) */
/*****
char BoundSet(char ServoID, char *NewLBound, char *NewUBound)
{
    char Data1,Data2;
    SendSetCommand((7<<5)|ServoID, 0x11, *NewLBound, *NewUBound);
    Data1 = GetByte(TIME_OUT2);
    Data2 = GetByte(TIME_OUT2);
    if((Data1==*NewLBound) && (Data2==*NewUBound)) return 1;
    return 0;
}

/*****
/* Send a bound read command to AI-motor */
/* Input : ServoID, *NewLBound, *NewUBound */
/* Return : 1(success), 0(fail) */
/*****
char BoundRead(char ServoID, char *LBound, char *UBound)
{
    SendSetCommand((7<<5)|ServoID, 0x12, 0, 0);
    *LBound = GetByte(TIME_OUT1);
    *UBound = GetByte(TIME_OUT1);
    if(*LBound<*UBound) return 1;
    return 0;
}
////////// Function declaration end //////////

```

3.5. Example of program(2)

```
/*=====*/  
/* AI MOTOR example code */  
/* description : Synchronous position send command function example */  
/* principal : Using synchronous position send function of AI MOTOR, control */  
/* several modules at the same time */  
/*=====*/
```

-refer to example of program(1)-

```
void main(void)  
{  
    // Motion table for ID 0~4 AI-motor(3 frames)  
    char table[5*3]= { 10, 0, 20,100, 20,  
                      125, 30, 0, 50,150,  
                      55,120,200, 88, 5};  
  
    Initialize(); // peripheral initialization  
  
    // synchronous position control ID 0~4 AI-motors at speed 0 (fastest)  
    SyncPosSend(4, 0, table, 1);  
    delay_ms(1000); // delay 1 second  
    // synchronous position control ID 0~2 AI-motors at speed 1 (fast)  
    SyncPosSend(2, 1, table, 0);  
    delay_ms(1000); // delay 1 second  
    // synchronous position control ID 0~1 AI-motors at speed 3 (slow)  
    SyncPosSend(1, 3, table, 2);  
    delay_ms(1000); // delay 1 second  
}
```